



PIEZO ULTRASONIC SENSOR

AW8T40-100A00 & AW8R40-100A00

This specifications is subject to change without notice.
Reprinting and copying of this specifications without prior written
permission from MOBICON HOLDINGS LTD are not permitted.

www.mobicon.com

7/F., New Trend Centre, 704 Prince Edward Road East, San Po Kong, Kowloon, Hong Kong.

PIEZO ULTRASONIC SENSOR SPECIFICATIONS

MODEL型号: AW8T40-100A00
AW8R40-100A00

SPECIFICATIONS规格:

| ITEM项目 | AW8T40-100A00 | AW8R40-100A00 |
|--|---------------|---------------|
| Center frequency中心频率 (KHz) | 40.0±1.0KHz | |
| Sound Pressure Level声压 (dB) 0dB=0.0002 μ bar | ≥110dB | ----- |
| Sensitivity灵敏度 (dB) 0dB=1volt/ μ bar | ----- | ≥-67dB |
| Beam Angle指向角 -6dB | 60°typical | |
| Capacitance静电容量 (pF) | 2000±30%pF | |
| Metals of case腔体材料 | Aluminum | |
| Max. Driving Voltage最大驱动电压(RMS) | 30Vrms | |
| Working Temperature工作温度(°C) | -20 to +70°C | |
| Storage Temperature贮存温度(°C) | -30 to +80°C | |

Note: "T" for Transmitter "R" for Receiver

DIMENSIONS尺寸:

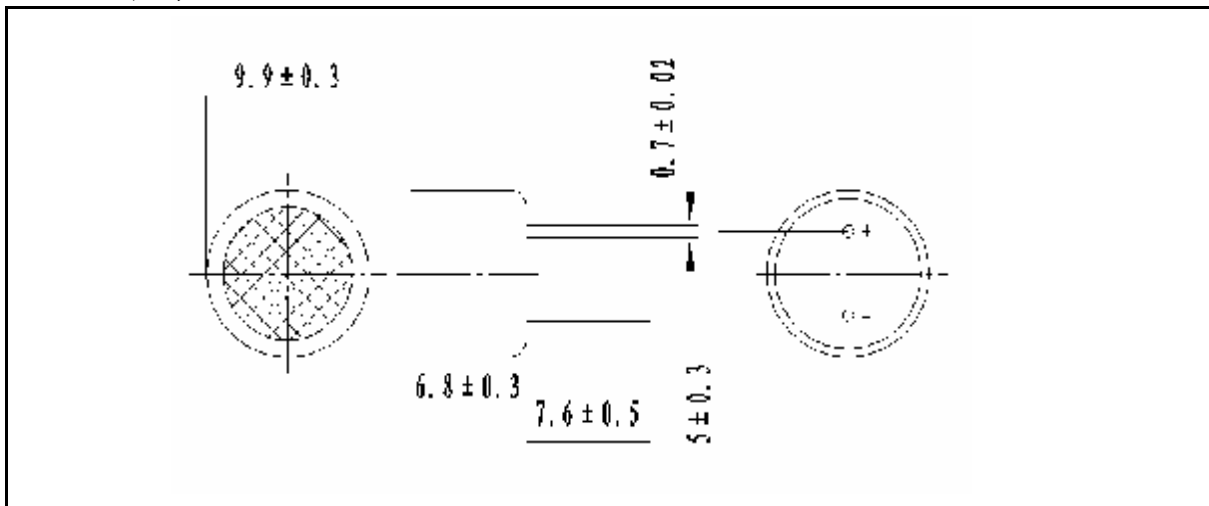

TESTING CONDITION AND INSTRUMENT测试条件和仪器

| ITEM项目 | TESTING CONDITION测试条件 | TESTING INSTRUMENT测试仪器 |
|------------------------|-----------------------|------------------------|
| Center frequency中心频率 | T=25~30°C H ≤85%RH | 压电换能器阻抗分析系统II型 |
| Sound Pressure Level声压 | at 40KHz/30cm/10Vrms | SoundCheck 4.1 |
| Sensitivity灵敏度 | at 40KHz | SoundCheck 4.1 |
| Beam Angle指向角 | ----- | SoundCheck 4.1 |
| Capacitance静电容量 | at 1KHz/1V 25°C | ZL5智能LCR测量仪 |

MEC

