

MOBICON

Electronic Components

PRODUCT SPECIFICATION

MEC

FREQUENCY COMPONENTS

SAW RESONATOR SPECIFICATION

MOBICON HOLDINGS LTD.		
Prepared By	Sign.	Approved By
Leo Wong		C.H. Wong

www.mobicon.com

MIEC

PART NO. :

HDR433MS2

ELECTRICAL CHARACTERISTICS

1.SCOPE

This specification shall cover the characteristics of 1-port SAW resonator with 433.92M used for remote-control security.

2. ELECTRICAL SPECIFICATION

DC Voltage VDC	10V
AC Voltage Vpp	10V50Hz/60Hz
Operation temperature	-40°C to +85°C
Storage temperature	-45°C to +85°C
RF Power Dissipation	0dBm

Electronic Characteristics

Item	Unites	Minimum	Typical	Maximum	
Center Frequency	MHz	433.845	433.920	433.995	
Insertion Loss	dB		1.5	2.5	
Quality Factor Unload Q			12,800		
50 Ω Loaded Q			2,000		
Temperature	Turnover Temperature	°C	10	25	40
Stability	Turnover Frequency	KHz		fo	
	Freq.temp.Coefficient	ppm/°C ²		0.032	
Frequency Aging	ppm/yr		<± 10		
DC. Insulation Resistance	M Ω	1.0			
RF Equivalent	Motional Resistance R1	Ω		18	26
	Motional Inductance L1	μ H		86	
	RLC Model	Motional Capacitance C1	pF		1.5
Pin 1 to Pin 2 Staic Capacitance	pF	1.7	2.0	2.3	
Transducer Static Capacitance	pF		1.9		

3. TEST CIRCUIT

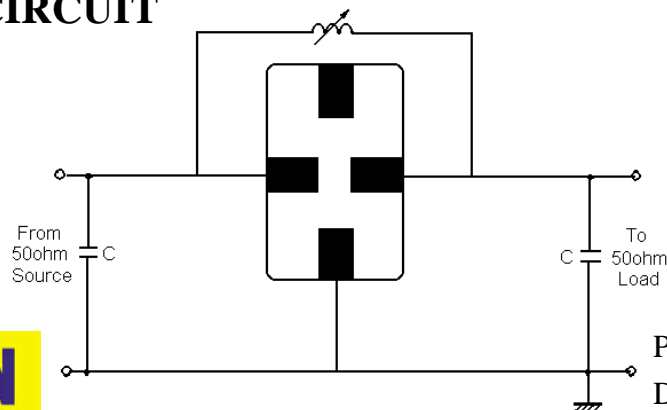

MEC

4. DIMENSION

4-1 Typical dimension(unit: mm)

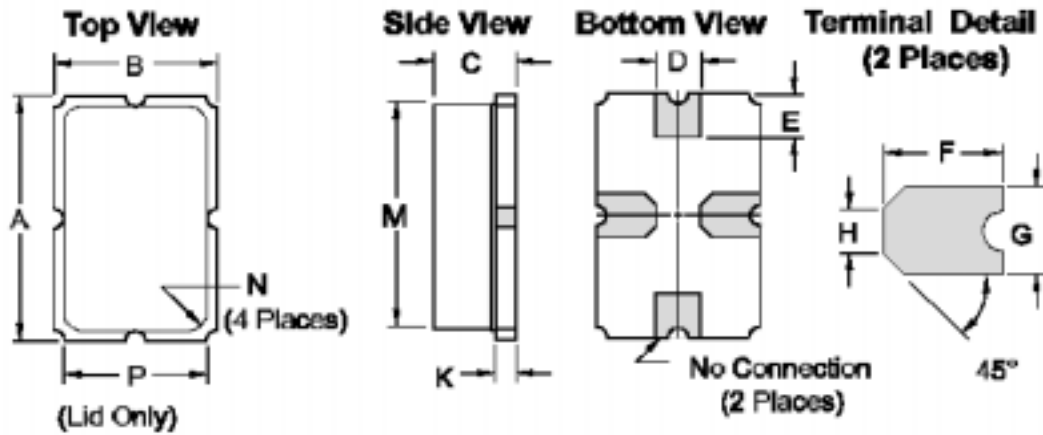

Dimensions	Millimeters		Inches	
	Min	Max	Min	Max
A		5.97		0.235
B		3.94		0.155
C		2.16		0.085
D	0.94	1.10	0.037	0.043
E	0.83	1.20	0.033	0.047
F	1.16	1.53	0.046	0.060
G	0.94	1.10	0.037	0.043
H	0.43	0.59	0.017	0.023
K	0.43	0.59	0.17	0.023
M		5.31		0.209
N	0.38	0.64	0.015	0.025
P		3.28		0.129

4-2 Typical circuit board land patter

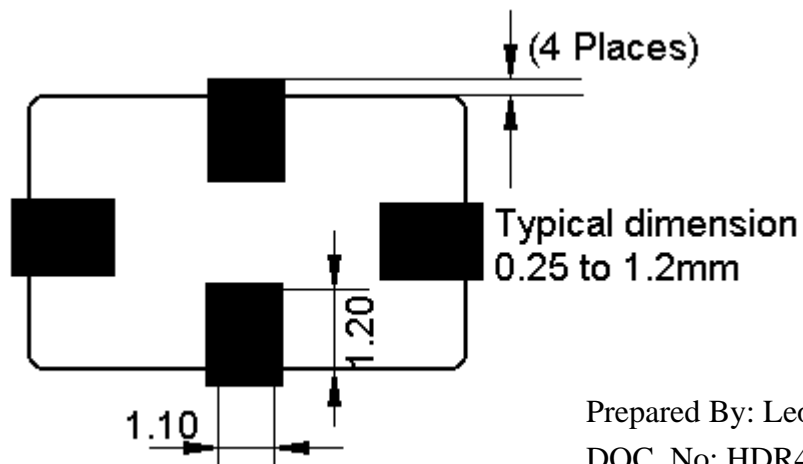

MIEC

5. ENVIRONMENTAL CHARACTERISTICS

5-1 Temperature cycling

Subject the device to a low temperature of -40°C for 30 minutes. Following by a high temperature of $+25^{\circ}\text{C}$ for 5 Minutes and a higher temperature of $+85^{\circ}\text{C}$ for 30 Minutes. Then release the device into the room conditions for 1 to 2 hours prior to the measurement. It shall meet the specifications in table 1.

5-2 Resistance to solder heat

Submerge the device terminals into the solder bath at $240^{\circ}\text{C} \pm 5^{\circ}\text{C}$ for 10 ± 1 sec. Then release the device into the room conditions for 4 hours. It shall meet the specifications in table 1.

5-3 Solderability

Submerge the device terminals into the solder bath at $245^{\circ}\text{C} \pm 5^{\circ}\text{C}$ for 5s, More than 95% area of the soldering pad must be covered with new solder. It shall meet the specifications in table 1.

5-4 Mechanical shock

Drop the device randomly onto the concrete floor from the height of 1 m 3 times. the filter shall fulfill the specifications in table 1.

5-5 Vibration

Subject the device to the vibration for 2 hour each in x,y and z axes with the amplitude of 1.5 mm at 10 to 55 hz. The filter shall fulfill the specifications in table 1.

6. REMARK

6.1 Static voltage

Static voltage between signal load & ground may cause deterioration & destruction of the component. Please avoid static voltage.

6.2 Ultrasonic cleaning

Ultrasonic vibration may cause deterioration & destruction of the component. Please avoid ultrasonic cleaning

6.3 Soldering

Only leads of component may be soldered. Please avoid soldering another part of component.

MEC

7. Typical Application Circuit

Typical low-power Transmitter Application

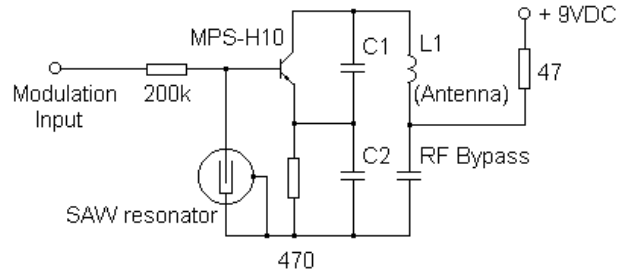

Typical Local Oscillator Application

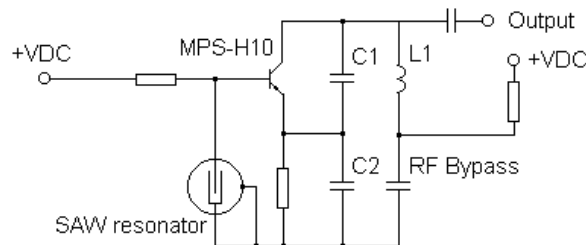

8. Packing

8.1 Dimensions

- (1) Carrier Tape: Figure 1
- (2) Reel: Figure 2
- (3) The product shall be packed properly not to be damaged during transportation and storage.

8.2 Reeling Quantity

3000 pcs/reel(13''), 1000pcs/reel(7'').

8.3 Taping Structure

- (1) The tape shall be wound around the reel in the direction shown below.

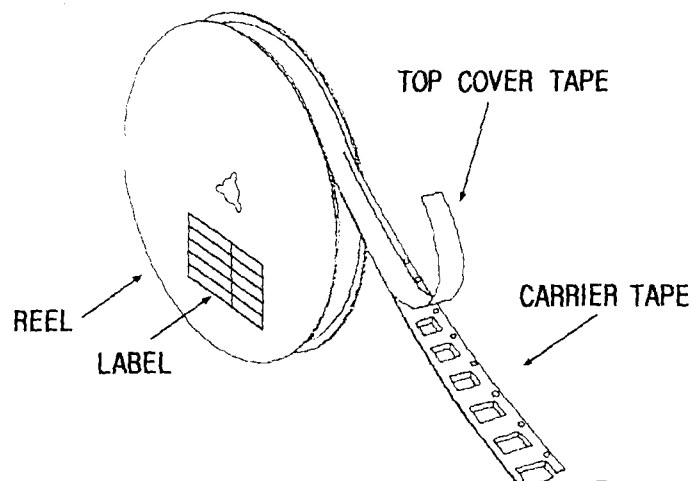

MEC

(2) Label

Device Name	
User Product Name	
Quantity	
Lot No.	

(3) Leader part and vacant position specifications.

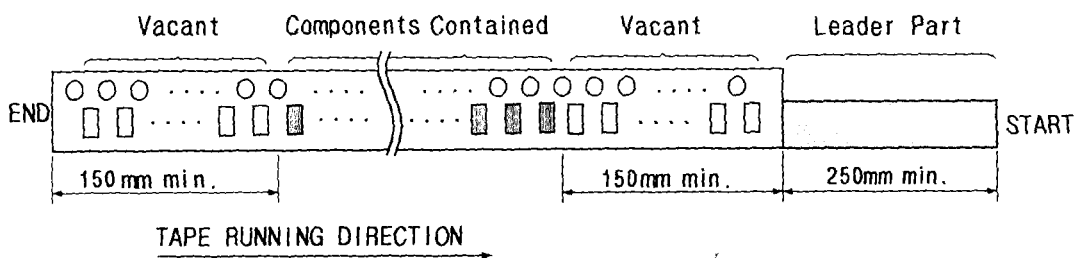

9. TAPE SPECIFICATIONS

9.1 Tensile Strength of Carrier Tape: 4.4N/mm width

9.2 Top Cover Tape Adhesion (See the below figure)

- (1) pull off angle: 0~15°
- (2) speed: 300mm/min.
- (3) force: 20~70g

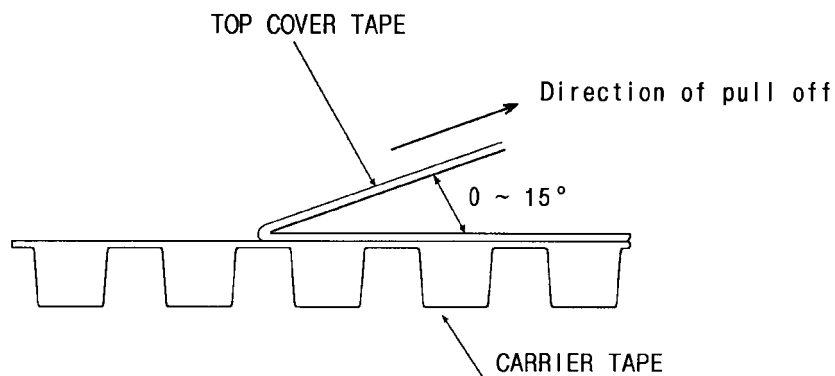

MEC

[Figure 1] Carrier Tape Dimensions

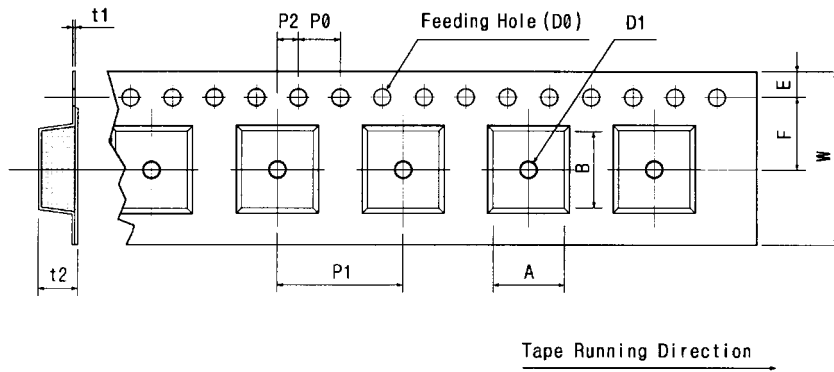

[Unit:mm]

W	F	E	P0	P1	P2	D0	D1	t1	t2	A	B
12.0	5.5	1.75	4.0	8.0	2.0	Ø1.5	Ø1.0	0.3	2.10	6.40	5.20
±0.3	±0.05	±0.1	±0.1	±0.1	±0.05	±0.1	±0.25	±0.05	±0.1	±0.1	±0.1

[Figure 2]

[Unit:mm]

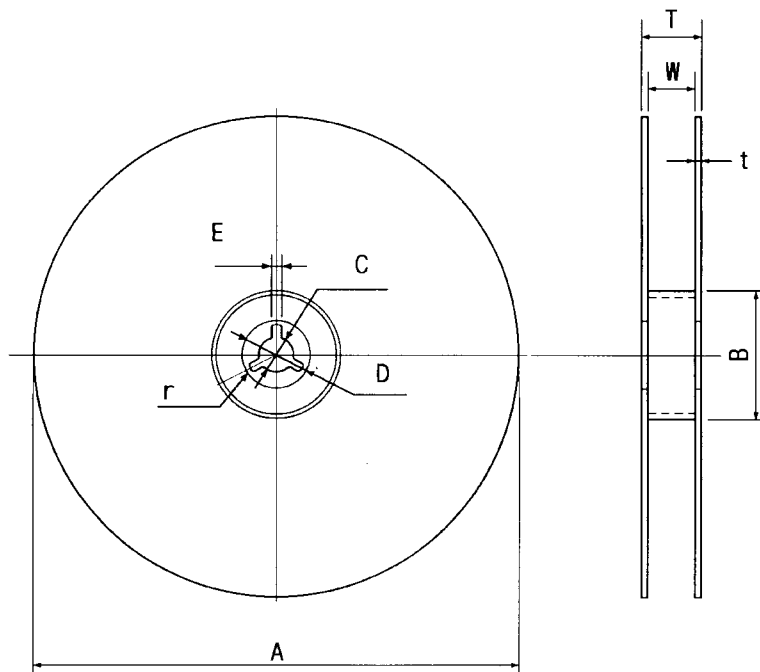

A	B	C	D	E	W	t	r
Ø330	Ø100	Ø13	Ø21	2	13	3	1.0
±1.0	±0.5	±0.5	±0.8	±0.5	±0.3	max.	max.

MEC

REVIEW OF SPECIFICATIONS

- 1) When something get doubtful with this specifications, we shall jointly work to get an agreement.
- 2) This specification limits the quality of the components as a single unit. Please insure the component is thoroughly evaluated in your application circuit.
- 3) Please do not use this component in any application that deviates from its intended use as noted within the specification. It may cause any mishaps.
- 4) Please return one of this specification after your signature of acceptance. In case of no return within 3 months from submission date. This specification should be treated as accepted.

When using our products, the following precautions should be taken.

- (1) Safety designing of apparatus or a system allowing for failures of electronic components used in the system

In general, failures will occur in electronic components at a certain probability. MOBICON HOLDINGS LTD makes every effort to improve the quality and reliability of electronic component products. However, it is impossible to completely eliminate the probability of failures. Therefore, when using MOBICON HOLDINGS LTD electronic component products, systems should be carefully designed to ensure redundancy in the event of an accident which would result in injury or death, fire, or social damage, to ensure the prevention of the spread of fire, and the prevention of faulty operation.
- (2) Quality Level of various kinds of parts, and equipment in which the parts can be utilized

Electronic components have a standard quality level unless otherwise specified.
- (3) This specifications is subject to change without notice.

The contents of this specifications are based on data which is correct as of 2002, and they may be changed without notice. If our products are used for mass-production design, please enquire consult with a member of our company's sales staff by way of precaution.
- (4) Reprinting and copying of this specifications without prior written permission from MOBICON HOLDINGS LTD are not permitted.
- (5) Industrial Property Problems

In the event any problems associated with industrial property of a third party arising as a result of the use of our products. MOBICON HOLDINGS LTD assumes no responsibility for problems other than problems directly associated with the constitution and manufacturing method of the products.



Prepared By: Leo Wong
DOC. No: Review of Spec