

# **MOBICON**

## **Electronic Components**

### **PRODUCT SPECIFICATION**

#### **MEC**

#### **FREQUENCY COMPONENTS**

**SAW RESONATOR SPECIFICATION**

<b>MOBICON HOLDINGS LTD.</b>		
<b>Prepared By</b>	<b>Sign.</b>	<b>Approved By</b>
Leo Wong		C.H. Wong

**[www.mobicon.com](http://www.mobicon.com)**

# MIEC

PART NO. :

HC49S-4.194304M1630F

## ELECTRICAL CHARACTERISTICS

### 1. SCOPE

This specification is applied to a SAW resonator designed for the stabilization of transmitters such as garage door openers and security transmitters.

### 2. ELECTRICAL SPECIFICATION

DC Voltage VDC	30V
AC Voltage Vpp	10V50Hz/60Hz
Operation temperature	-40 to +85
Storage temperature	-45 to +85
RF Power Dissipation	0dBm

#### Electronic Characteristics

Item	Unites	Minimum	Typical	Maximum	Sym	
Center Frequency	MHz	317.925	318.000	318.075	f <sub>c</sub>	
Insertion Loss (in 50ohm system)	dB		1.5	2.2	IL	
Quality Factor	Unloaded Q		13,900		Q <sub>U</sub>	
	50 LoadedQ		2,000		Q <sub>L</sub>	
Temperature	Turnover Temperature	10	25	40	To	
Stability	Turnover Frequency	MHz	f <sub>c</sub>		fo	
	Frequency Temperature Coefficient	ppm/ °C	0.037		FTC	
Frequency Aging	Absolute Value during the First year	ppm/yr	10		f <sub>A</sub>	
DC Insulation Resistance between any two Pins		M	1.0			
RF Equivalent RLC Model	Motional Resistance		19	26	R <sub>m</sub>	
	Motional Inductance	μH	133.811		L <sub>m</sub>	
	Motional Capacitance	fH	2.05070		C <sub>m</sub>	
	Pin 1 to pin2 Static Capacitance	pF	1.5	2.0	2.5	Co
	Transducer Static Capacitance	pF		2.5		Cp

# MEC

## 3. TEST CIRCUIT

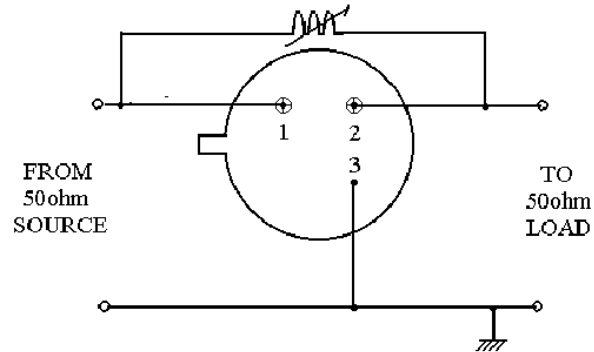

## 4. DIMENSION

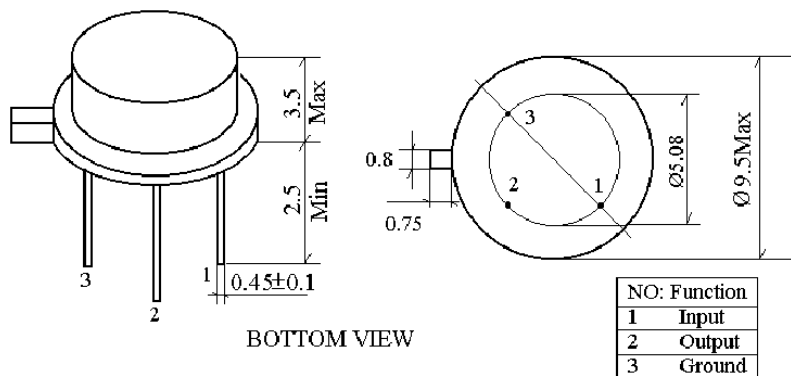

## 5. ENVIRONMENTAL CHARACTERISTICS

### 5-1 High temperature exposure

Subject the device to +85 for 16 hours. Then release the filter into the room conditions for 24 hours prior to the measurement. It shall fulfill the specifications in table 1.

### 5-2 Low temperature exposure

Subject the device to -20 for 16 hours. Then release the device into the room conditions for 24 hours prior to the measurement. It shall fulfill the specifications in table 1.

### 5-3 Temperature cycling

Subject the device to a low temperature of -40 for 30 minutes. Following by a high temperature of +80 for 30 Minutes. Then release the device into the room conditions for 24 hours prior to the measurement. It shall meet the

# MEC

specifications in table 1.

## 5-4 Resistance to solder heat

Dip the device terminals no closer than 1.5mm into the solder bath at  $260 \pm 10$  for  $10 \pm 1$  sec. Then release the device into the room conditions for 4 hours. The device shall meet the specifications in table 1.

## 5-5 Solderability

Subject the device terminals into the solder bath at  $245 \pm 5$  for 5s, More than 95% area of the terminals must be covered with new solder. It shall meet the specifications in table 1.

## 5-6 Mechanical shock

Drop the device randomly onto the concrete floor from the height of 1m 3 times. the device shall fulfill the specifications in table 1.

## 5-7 Vibration

Subject the device to the vibration for 1 hour each in x,y and z axes with the amplitude of 1.5 mm at 10 to 55 Hz. The device shall fulfill the specifications in table 1.

## 5-8 Lead fatigue

### 5-8-1 Pulling test

Weight along with the direction of lead without an shock 1kg. The device shall satisfy all the initial Characteristics.

### 5-8-2 Bending test

Lead shall be subject to withstand against 90 bending with 450g weight in the direction of thickness. This operation shall be done toward both direction. The device shall show no evidence of damage and shall satisfy all the initial electrical characteristics.

## 6. REMARK

### 6.1 Static voltage

Static voltage between signal load & ground may cause deterioration & destruction of the component. Please avoid static voltage.

### 6.2 Ultrasonic cleaning

Ultrasonic vibration may cause deterioration & destruction of the component. Please avoid ultrasonic cleaning

### 6.3 Soldering

Only leads of component may be solded. Please avoid soldering another part of component.

# MEC

## REVIEW OF SPECIFICATIONS

- 1) When something get doubtful with this specifications, we shall jointly work to get an agreement.
- 2) This specification limits the quality of the components as a single unit. Please insure the component is thoroughly evaluated in your application circuit.
- 3) Please do not use this component in any application that deviates from its intended use as noted within the specification. It may cause any mishaps.
- 4) Please return one of this specification after your signature of acceptance. In case of no return within 3 months from submission date. This specification should be treated as accepted.

### **When using our products, the following precautions should be taken.**

- (1) Safety designing of apparatus or a system allowing for failures of electronic components used in the system  
In general, failures will occur in electronic components at a certain probability. MOBICON HOLDINGS LTD makes every effort to improve the quality and reliability of electronic component products. However, it is impossible to completely eliminate the probability of failures. Therefore, when using MOBICON HOLDINGS LTD electronic component products, systems should be carefully designed to ensure redundancy in the event of an accident which would result in injury or death, fire, or social damage, to ensure the prevention of the spread of fire, and the prevention of faulty operation.
- (2) Quality Level of various kinds of parts, and equipment in which the parts can be utilized  
Electronic components have a standard quality level unless otherwise specified.
- (3) This specifications is subject to change without notice.  
The contents of this specifications are based on data which is correct as of 2002, and they may be changed without notice. If our products are used for mass-production design, please enquire consult with a member of our company's sales staff by way of precaution.
- (4) Reprinting and copying of this specifications without prior written permission from MOBICON HOLDINGS LTD are not permitted.
- (5) Industrial Property Problems  
In the event any problems associated with industrial property of a third party arising as a result of the use of our products. MOBICON HOLDINGS LTD assumes no responsibility for problems other than problems directly associated with the constitution and manufacturing method of the products.



Prepared By: Leo Wong  
DOC. No: Review of Spec