



## **ZTT20.00MX**

### **SPECIFICATION OF CERAMIC RESONATOR**

This specifications is subject to change without notice.  
Reprinting and copying of this specifications without prior written  
permission from MOBICON HOLDINGS LTD are not permitted.

**[www.mobicon.com](http://www.mobicon.com)**

7/F., New Trend Centre, 704 Prince Edward Road East, San Po Kong, Kowloon, Hong Kong.

**MEC**

1 . SCOPE

This specification shall cover the characteristics of the ceramic resonator with the type ZTT20.00MX50ED0F-B0.

2 . PART NO.

PART NUMBER	PREVIOUS PART NUMBER
ZTT20.00MX50ED0F-B0	ZTT20.00MX
CUSTOMER PART NO	SPECIFICATION NO

3 . OUTLINE DIMENSIONS AND MARK

3.1 Appearance: No visible damage and dirt.

3.2 Construction: Leads are soldered on electrode and body is molded by resin.

3.3 The products conform to the RoHS directive and national environment protection law.

3.4 Dimensions and mark

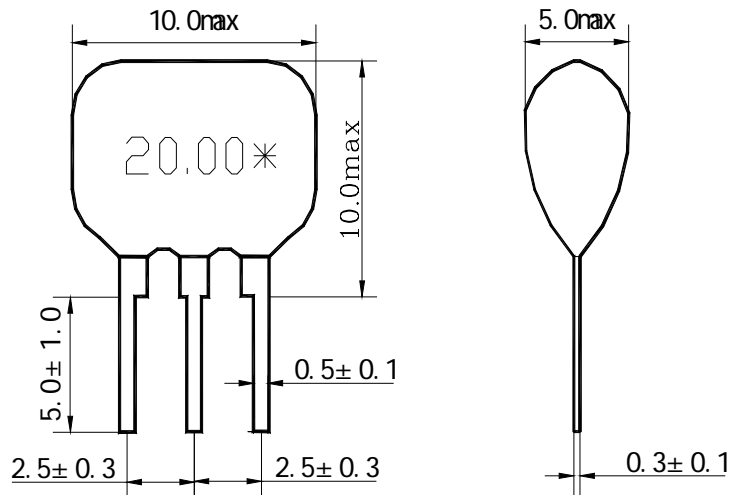

INPUT GROUND OUTPUT  
\*: EIAJ MONTHLY CODE



## 4 . ELECTRICAL SPECIFICATIONS

### 4.1 RATING

Items	Requirement
Withstanding Voltage (V)	50 (DC , 1min)
Insulation Resistance Ri, ( M ) min.	100 ( 10V , 1min )
Operating temperature	-25 ~ +85
Storage temperature	-55 ~ +85
Rating Voltage UR ( V )	6V DC
	15V p-p

### 4.2 ELECTRICAL SPECIFICATIONS

Items	Requirement
Oscillation Frequency Fosc ( MHz )	20.000
Frequency Accuracy ( % )	± 0.5
Resonant Impedance Ro ( Ω ) max.	30
Temperature Coefficient of Oscillation Frequency ( % ) max.	± 0.3 ( Oscillation Frequency drift , -25 ~ +85 )
Aging Rate ( % ) max.	± 0.3 ( For Ten Years )

## 5 . TEST

### 5.1 Test Conditions

Parts shall be tested under the condition ( Temp. : 20±15 , Humidity : 65±20% R.H.) unless the standard condition(Temp. : 25±2 , Humidity : 65±5% R.H.) is regulated to measure.

### 5.2 Test Circuit

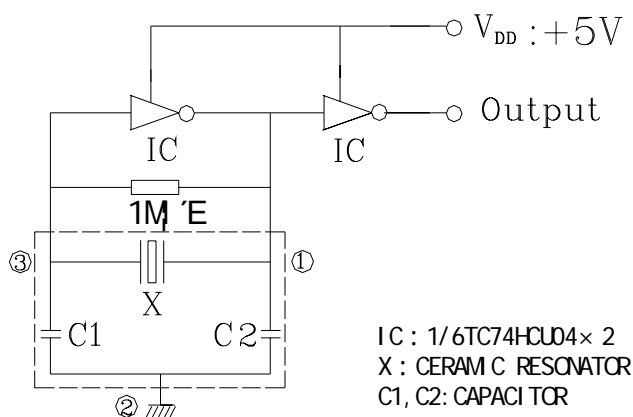

## 6 PHYSICAL AND ENVIRONMENTAL CHARACTERISTICS

No.	Item	Condition of Test	Performance Requirement	
6.1	Humidity	Subject the resonator at $40 \pm 2$ and 90%-95% R.H. for 500h, resonator shall be measured after being placed in natural conditions for 1h.	It shall fulfill Table 1.	
6.2	High Temperature Exposure	Subject the resonator to $85 \pm 2$ for 500h, resonator shall be measured after being placed in natural conditions for 1h.	It shall fulfill Table 1.	
6.3	Low Temperature Exposure	Subject the resonator to $-25 \pm 2$ for 500h, resonator shall be measured after being placed in natural conditions for 1h.	It shall fulfill Table 1.	
6.4	Temperature Cycling	After temperature cycling of blow table was performed 5 times, resonator shall be measured after being placed in natural conditions for 1h.	It shall fulfill Table 1.	
		Temperature		Time
		$-25 \pm 3$		$30 \pm 3$ min
		$85 \pm 3$		$30 \pm 3$ min
6.5	Vibration	Subject the resonator to vibration for 2h. Each in x y and z axis with the amplitude of 1.5mm, The frequency shall be varied uniformly between the limits of 10Hz-55Hz-10Hz and then resonator shall be measured.	It shall fulfill Table 1.	
6.6	Mechanical Shock	Resonator shall be measured after 3 times random dropping from the height of 1m on concrete floor.	No visible damage and it shall fulfill Table 1.	
6.7	Resistance to Soldering Heat	Lead terminals are immersed up to 2 mm from resonator's body in soldering bath of $260 \pm 5$ for $10s \pm 1s$ and then resonator shall be measured after being placed in natural conditions for 1h.	It shall fulfill Table 1.	
6.8	Solderability	Lead terminals are immersed up to 2mm from resonator's body in soldering bath of $250 \pm 5$ for $3s \pm 0.5s$ .	More than 95% of the terminal surface of the filter shall be covered with fresh solder.	



## 6 . ENVIRONMENTAL TEST

No.	Item	Condition of Test	Performance Requirements
6.9	Terminal Strength		
6.9.1	Terminal Pulling	Force of 5N is applied to each lead in axial direction for 10s $\pm$ 1s.	
6.9.2	Terminal Bending	When force of 5N is applied to each lead in axial direction,the lead shall folded up 90 ° from the axial direction and folded back to the axial direction. The speed of folding shall be each 3s.	No visible damage and it shall fulfill Table 1.

Table 1

Item	Specification after test
Oscillation Frequency Change fosc/fosc (%) max.	$\pm 0.3$
Resonant Impedance Ro ( $\Omega$ ) max.	30
The limits in the above table are referenced to the initial measurements.	



## 7 . PACKAGE

To protect the products in storage and transportation , it is necessary to pack them ( outer and inner package ). On paper pack, the following requirements are requested.

### 7.1 Dimensions and Mark

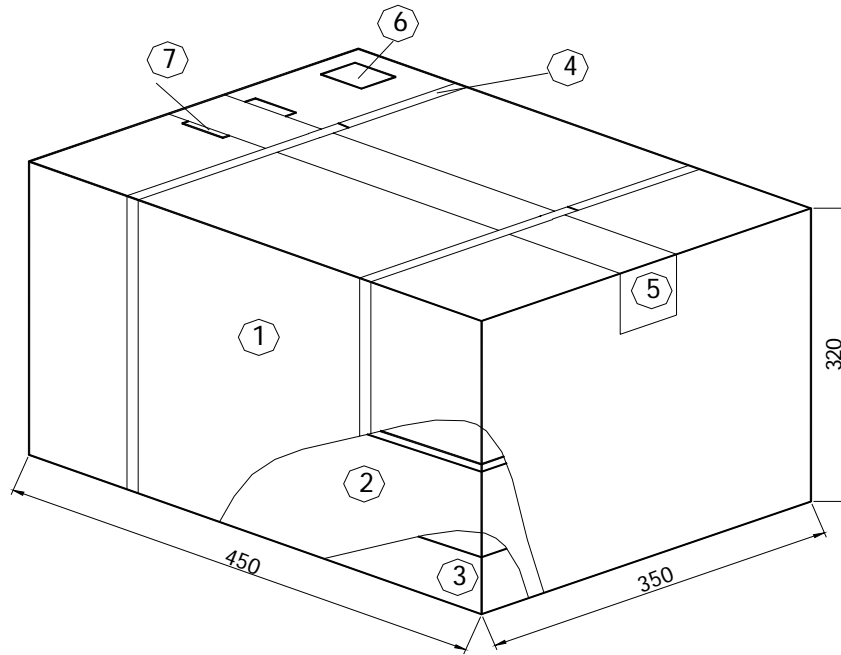

NO.	Name	Quantity
	Package	1
	Box	2
	Inner Box	40
	Belt	2.9 m
	Adhesive tape	1.2 m
	Label	1
	Certificate of approval	1
	Company name ,Address etc.	

### 7.2 Section of Package

Package is made of corrugated paper with thickness of 0.8cm. Package has 2 boxes, each has 20 inner boxes.

### 7.3 Quantity of Package

Per plastic bag                      500 pieces



Per inner box                    2 plastic bag  
 Per package                    40 inner boxes  
 ( 40000 pieces of piezoelectric ceramic part )

#### 7.4 Inner Package

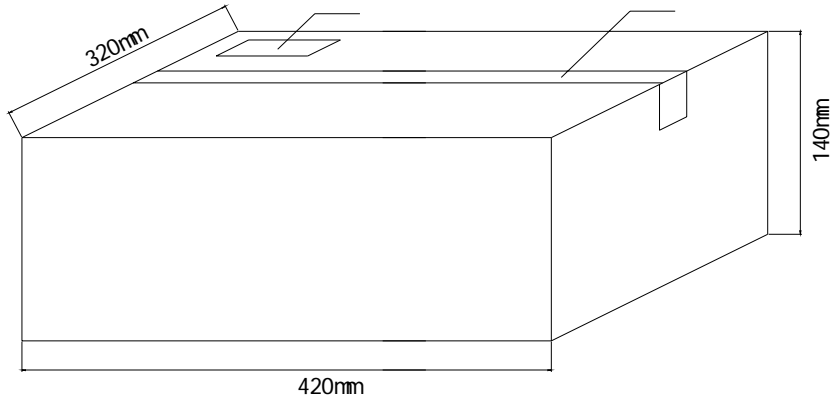

NO.	Name	Quantity
	Inner package	1
	Adhesive tape	1.2 m
	Label	1

#### 7.5 Inner Box Dimensions

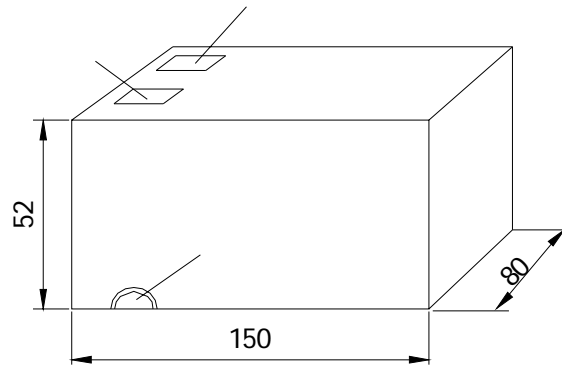

NO.	Name	Quantity
	Inner Box	1
	RoHS Label	1
	QC Label	1
	Label	1



## 8 . EIAJ Monthly Code

2005 / 2007 / 2009		2006 / 2008 / 2010	
MONTH	CODE	MONTH	CODE
JAN	A	JAN	N
FEB	B	FEB	P
MAR	C	MAR	Q
APR	D	APR	R
MAY	E	MAY	S
JUN	F	JUN	T
JUL	G	JUL	U
AUG	H	AUG	V
SEP	J	SEP	W
OCT	K	OCT	X
NOV	L	NOV	Y
DEC	M	DEC	Z

## 9 . OTHER

### 9.1 Caution

9.1.1 Don't apply excess mechanical stress to the component and terminals at soldering. Do not use this product with bend.

9.1.2 Do not clean or wash the component for it is not hermetically sealed.

9.1.3 Do not use strong acidity flux , more than 0.2wt% chlorine content , in flow soldering.

9.1.4 Don't be close to fire.

9.1.5 All kinds of re-flow soldering must not be applied on the component.

9.1.6 This specification mentions the quality of the component as a single unit. Please insure the component is thoroughly evaluated in your application circuit

9.1.7 Expire date (Shelf life) of the products is 12 months after delivery under the conditions of a sealed and an unopened package. Please use the products within six months after delivery. If you store the products for a long time (more than six months), use carefully because the products may be degraded in the solderability or rusty. Please confirm solderability and characteristics for the products regularly.

9.1.8 Please contact us before using the product as automobile electronic component.

### 9.2 Notice

9.2.1 Please return one of this specification after your signature of acceptance.

9.2.2 When something gets doubtful with this specifications, we shall jointly work to get an agreement.

