

# **MOBICON**

## **Electronic Components**

### **PRODUCT SPECIFICATION**

#### **MEC RESONATOR**

#### **FREQUENCY COMPONENTS**

#### **ZTT Series RESONATOR SPECIFICATION**

This specifications is subject to change without notice.

<b>MOBICON HOLDINGS LTD.</b>		
<b>Prepared By</b>	<b>Sign.</b>	<b>Approved By</b>
Leo Wong		C.H. Wong

Reprinting and copying of this specifications without prior written permission from MOBICON HOLDINGS LTD are not permitted.

**[www.mobicon.com](http://www.mobicon.com)**

# MECC

## CERAMIC RESONATOR SPECIFICATION

**PART NO. :**

**ZTT 4.43 MG**

### ELECTRICAL CHARACTERISTICS

1. Oscillation Frequency (Fosc)	4.43MHz $\pm$ 0.5%
2. Resonant Impedance (Ro)	30 Ohm max.
3. Temperature Coefficient of Oscillation Frequency	$\pm$ 0.3% max. (-20°C ~ +80°C)
4. Withstanding Voltage	100VDC @ 5 sec. max.
5. Rating Voltage:	
D.C. Voltage	50V
A.C. Voltage	20Vpp
6. Insulation Resistance	100 MOhm min. @10V DC
7. Operating Temperature	-20°C ~ +80°C
8. Storage Temperature	-35°C ~ +85°C
9. Aging Rate (Fosc)	$\pm$ 0.3% max. for 10 years

### MEASUREMENT

#### Measurement Condition

The reference temperature shall be 25°C  $\pm$  2°C. The measurement shall be performed at the temperature range of 5°C ~ 35°C unless otherwise the result is doubtful.

### MEASUREMENT CIRCUIT AND EQUIPMENT

Oscillating frequency shall be measured by the standard test circuit.

Resonant impedance shall be measured by *HP8751A Network Analyzer*.

#### Mechanical Dimensions (Unit = mm)

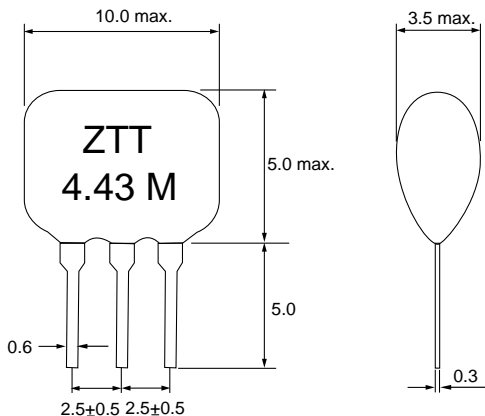

#### Test Circuit ( C<sub>1</sub>, C<sub>2</sub> = 30pF )

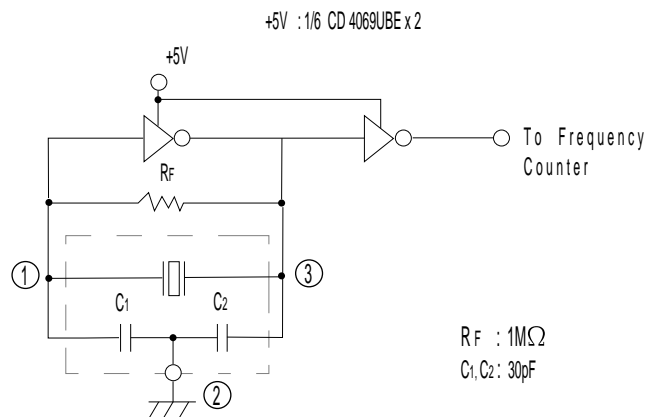

R<sub>F</sub> : 1M $\Omega$   
C<sub>1</sub>, C<sub>2</sub> : 30pF



Prepared By: Leo Wong  
DOC. No: ZTT4.43MG

# MEC

## CERAMIC RESONATOR SPECIFICATION

### PHYSICAL AND ENVIRONMENTAL CHARACTERISTICS

No.	Item	Condition of Test	Performance Requirements
1	Humidity	Keep the resonator at $40 \pm 2^{\circ}\text{C}$ and 90~95% RH for $96 \pm 4$ hours. Then release the resonator into the room condition for 1 hour prior to the measurement.	<i>It shall fulfill the specifications in Table 1.</i>
2	Vibration	Subject the resonator to vibration for 2 hours each in X, Y and Z axis with the amplitude of 1.5mm, the frequency shall be varied uniformly between the limits of 10~55Hz.	
3	Mechanical Shock	Drop the resonator randomly onto a wooden floor from the height of 100cm 3 times.	
4	Resistance to Solder Heat	Dip the resonator terminals no closer than 2mm into the solder bath $260 \pm 5^{\circ}\text{C}$ for $10 \pm 1$ seconds.	
5	Soldering Test	Passed through the reflow oven under the following condition, and left at room temperature for 1 hour before measurement.	
		Temperature at the surface of the substrate:	
		Preheat $150 \pm 5^{\circ}\text{C}$	$60 \pm 10$ sec.
		Peak $240 \pm 5^{\circ}\text{C}$	$10 \pm 3$ sec.
6	High Temperature Exposure	Subject the resonator to $80 \pm 5^{\circ}\text{C}$ for $96 \pm 4$ hours. Then release the resonator into the room conditions for 1 hour prior to the measurement.	

# MEC

## CERAMIC RESONATOR SPECIFICATION

7	Low Temperature	Subject the resonator to $-20 \pm 5^{\circ}\text{C}$ for $96 \pm 4$ hours. Then release the resonator into the room conditions for 1 hour prior to the measurement.	<i>It shall fulfill the specifications in Table 1.</i>
8	Temperature Cycling	Subject the resonator to $-20^{\circ}\text{C}$ for 30 min. followed by a high temperature of $85^{\circ}\text{C}$ for 30 min. cycling shall be repeated 5 times with a transfer time of 15 seconds. At the room temperature for 1 hour prior to the measurement.	
9	Solderability	Dipped in $230 \pm 5^{\circ}\text{C}$ seconds with resin flux. (25wt% ethanol solution)	The terminals shall be at least 95% covered by solder.
10	Board Bending	Mount a glass epoxy board (width = 40mm, thickness = 1.6mm), then bend it to 1mm displacement and keep it for 5 seconds. (See the following figure)	Mechanical damage such as breaks shall not occur.

**TABLE 1**

Item	Specification
Oscillation Frequency Change	$\Delta F / F_{osc} \leq 0.3\%$ max.
Resonant Impedance	Within $\pm 10 \Omega$

# MEC

## REVIEW OF SPECIFICATIONS

- 1) When something get doubtful with this specifications, we shall jointly work to get an agreement.
- 2) This specification limits the quality of the components as a single unit. Please insure the component is thoroughly evaluated in your application circuit.
- 3) Please do not use this component in any application that deviates from its intended use as noted within the specification. It may cause any mishaps.
- 4) Please return one of this specification after your signature of acceptance. In case of no return within 3 months from submission date. This specification should be treated as accepted.

### **When using our products, the following precautions should be taken.**

- (1) Safety designing of apparatus or a system allowing for failures of electronic components used in the system  

In general, failures will occur in electronic components at a certain probability. MOBICON HOLDINGS LTD makes every effort to improve the quality and reliability of electronic component products. However, it is impossible to completely eliminate the probability of failures. Therefore, when using MOBICON HOLDINGS LTD electronic component products, systems should be carefully designed to ensure redundancy in the event of an accident which would result in injury or death, fire, or social damage, to ensure the prevention of the spread of fire, and the prevention of faulty operation.
- (2) Quality Level of various kinds of parts, and equipment in which the parts can be utilized  

Electronic components have a standard quality level unless otherwise specified.
- (3) This specifications is subject to change without notice.  

The contents of this specifications are based on data which is correct as of 2002, and they may be changed without notice. If our products are used for mass-production design, please enquire consult with a member of our company's sales staff by way of precaution.
- (4) Reprinting and copying of this specifications without prior written permission from MOBICON HOLDINGS LTD are not permitted.
- (5) Industrial Property Problems  

In the event any problems associated with industrial property of a third party arising as a result of the use of our products. MOBICON HOLDINGS LTD assumes no responsibility for problems other than problems directly associated with the constitution and manufacturing method of the products.



Prepared By: Leo Wong  
DOC. No: Review of Spec