



QJ—12137F—2006

SPECIFICATION OF PRODUCTS

CUSTOMER : _____

PRODUCT NAME : CERAMIC RESONATOR

PART NUMBER : ZTTCS9.83MT

Approved by	Checked by	Drawn by

This specifications is subject to change without notice.
Reprinting and copying of this specifications without prior written permission from MOBICON HOLDINGS LTD are not permitted.

www.mobicon.com

7/F., New Trend Centre, 704 Prince Edward Road East, San Po Kong, Kowloon, Hong Kong.



1 SCOPE

This specification shall cover the characteristics of the ceramic resonator with the type ZTTCS9.83MT.

2 PART NO.

PART NUMBER	CUSTOMER PART NO	SPECIFICATION NO
ZTTCS9.83MT		

3 OUTLINE DRAWING AND DIMENSIONS

3.1 Appearance: No visible damage and dirt.

3.2 Except the chip(ceramic element, ceramic base, capacitance slice), the materials don't contain lead.

3.3 Dimensions

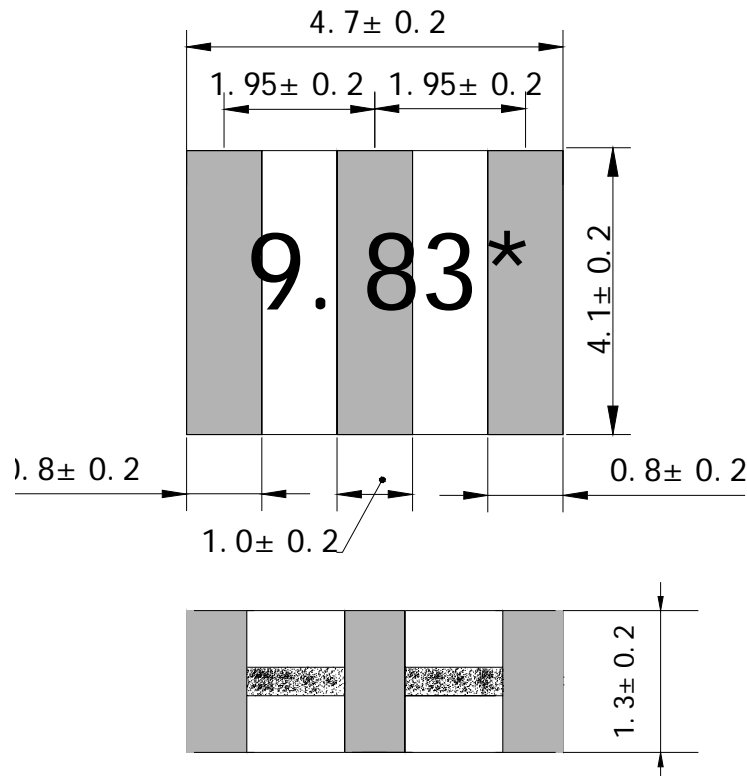

*:EIAJ MONTHLY CODE



4 RATING AND ELECTRICAL SPECIFICATIONS

4.1 RATING

Items	Content
Withstanding Voltage (V)	50 (DC , 1min)
Insulation Resistance Ri, (M) min.	100 (100V , 1min)
Operating Temperature Range ()	-25 ~ +85
Storage Temperature Range ()	-55 ~ +85

4.2 ELECTRICAL SPECIFICATIONS

Oscillation Frequency Fosc (MHz)	9.830
Frequency Accuracy (%)	± 0.5
Resonant Impedance Ro (Ω) max.	30
Temperature Coefficient of Oscillation Frequency (%) max.	± 0.3 (Oscillation Frequency drift , -25 ~ +85)
Rating Voltage UR (V) max.	6V DC
	15V p-p
Aging Rate (%) max.	± 0.3 (For Ten Years)

5 MEASUREMENT

5.1 Measurement Conditions

Parts shall be measured under a condition (Temp. : 20 ±15 , Humidity : 65%±20% R.H.) unless the standard condition(Temp. : 25 ±3 , Humidity : 65%±5% R.H.) is regulated to measure.

5.2 Test Circuit

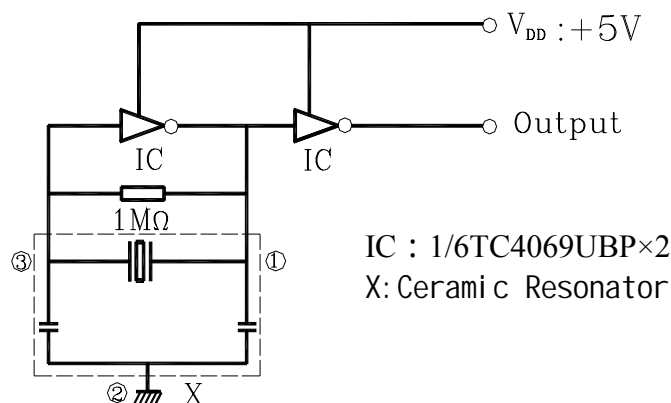

6 PHYSICAL AND ENVIRONMENTAL CHARACTERISTICS

No	Item	Condition of Test	Performance Requirements	
6.1	Humidity	Keep the resonator at 40 ± 2 and 90%-95% RH for 96h \pm 4h. Then Release the resonator into the room Condition for 1h prior to the Measurement.	It shall fulfill the specifications in Table 1.	
6.2	Vibration	Subject the resonator to vibration for 2h each in x、 y and z axis With the amplitude of 1.5mm, the frequency shall be varied uniformly between the limits of 10 Hz—55Hz.	It shall fulfill the specifications in Table 1.	
6.3	Mechanical Shock	Drop the resonator randomly onto a wooden floor from the height of 100cm 3 times.	It shall fulfill the specifications in Table 1.	
6.4	Soldering Test	Passed through the re-flow oven under the following condition and left at room temperature for 1h before measurement.		It shall fulfill the specifications in Table 1.
		Temperature at the surface of the substrate	Time	
		Preheat 150 ± 5	80s-120 s	
		Solder- ing	230 250 (peak:260)	
6.5	Solder Ability	Dipped in 245 ± 5 solder bath for 3s \pm 0.5 s with rosin flux (25wt% ethanol solution.)	The terminals shall be at least 95% covered by solder.	
6.6	High Temperature Exposure	Subject the resonator to 80 ± 5 for 96s, then release the resonator into the room conditions for 1h prior to the measurement.	It shall fulfill the specifications in Table 1.	
6.7	Low Temperature Exposure	Subject the resonator to -20 ± 5 for 96h, then release the resonator into the room conditions for 1h prior to the measurement.	It shall fulfill the specifications in Table 1.	



6 PHYSICAL AND ENVIRONMENTAL CHARACTERISTICS

No	Item	Condition of Test	Performance Requirements
6.8	Temperature Cycling	Subject the resonator to -40 for 30 min. followed by a high temperature of 85 for 30 min. Cycling shall be repeated 5 times with a transfer time of 15s. At the room temperature for 1h prior to the measurement.	It shall fulfill the specifications in Table 1.
6.9	Board Bending	Mount a glass-epoxy board (Width=40mm,thickness=1.6mm),then bend it to 1mm displacement and keep it for 5s. (See the following figure) 	Mechanical damage such as breaks shall not occur.

Table 1

Item	Specification after test
Oscillation Frequency Change Fosc/Fosc (%) max	±0.3
Resonant Impedance () max	40
The limits in the above table are referenced to the initial measurements.	

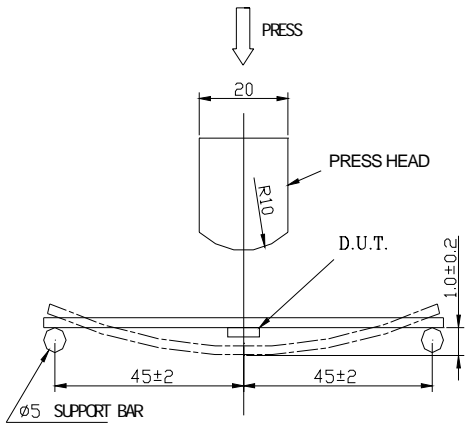

7 RECOMMENDED LAND PATTERN AND REFLOW SOLDERING STANDARD CONDITIONS

7.1 Recommended land pattern

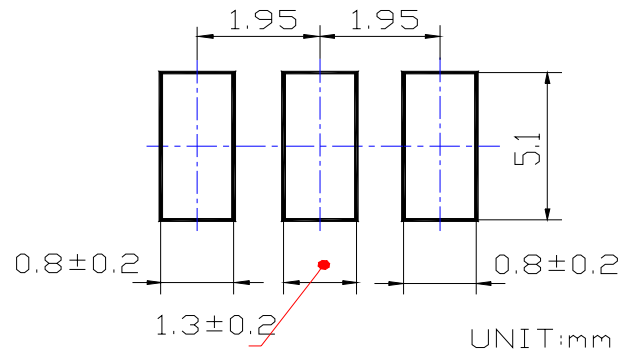

7.2 Recommended reflow soldering standard conditions

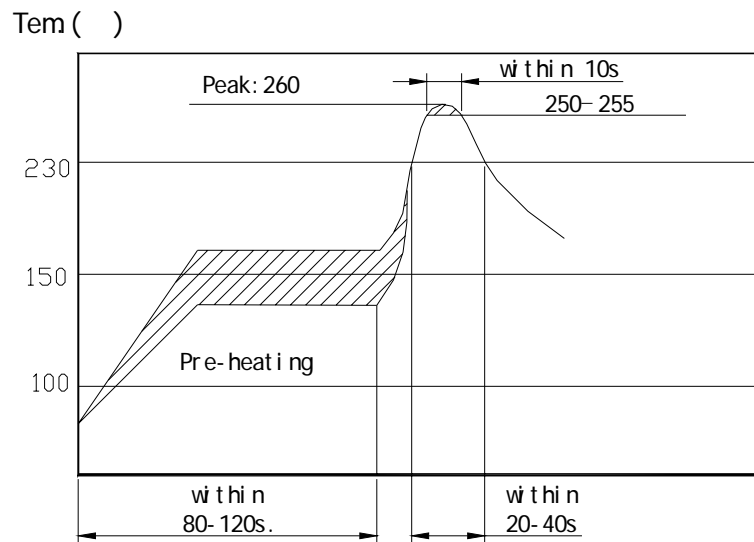

8 PACKAGE

To protect the products in storage and transportation , it is necessary to pack them(outer and inner package).On paper pack, the following requirements are requested.

8.1 Dimensions and Mark

At the end of package, the warning (moisture proof, upward put) should be stick to it.

Dimensions and Mark (see below)

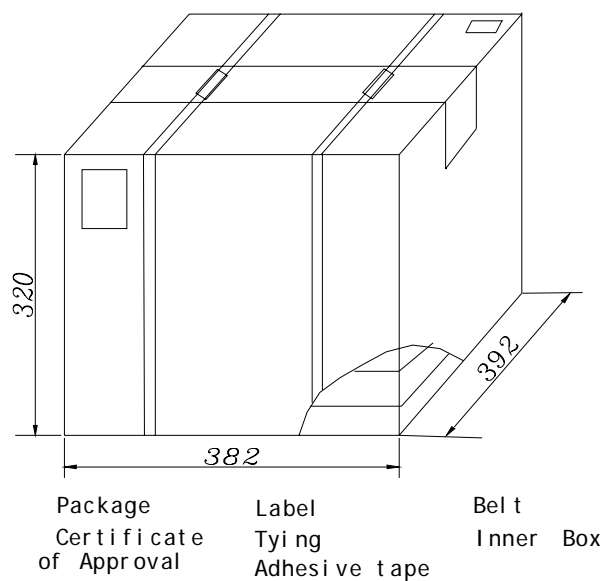

8.2 Section of package

Package is made of corrugated paper with thickness of 0.8cm.Package has 12 inner boxes, each box has 5 reels (each reel for plastic bag).

8.3 Quantity of package

Per plastic reel	1000 pieces of piezoelectric ceramic part
Per inner box	5 reels
Per package	12 inner boxes
(60000 pieces of piezoelectric ceramic part)	

8.4Reel



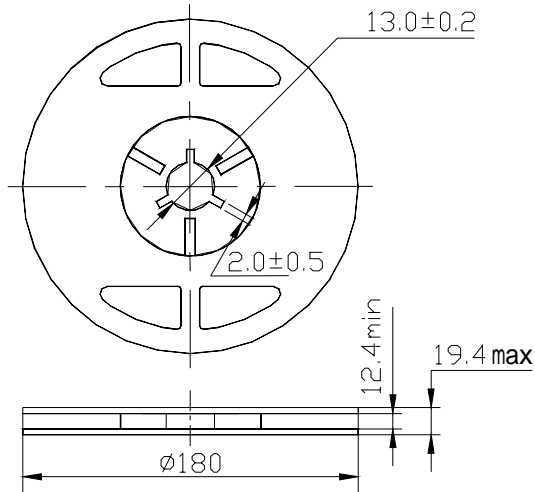

8.5 Packing Method Sketch Map

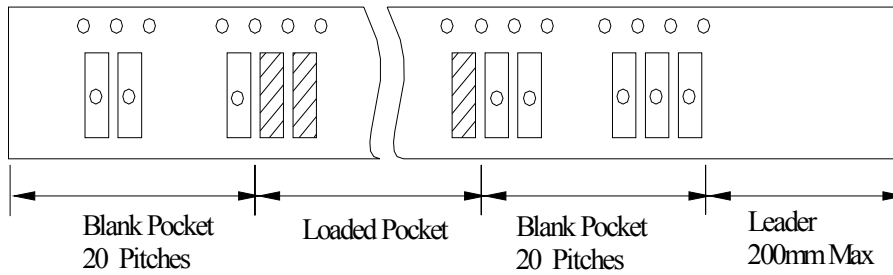

8.6 Test Condition Of Peeling Strength

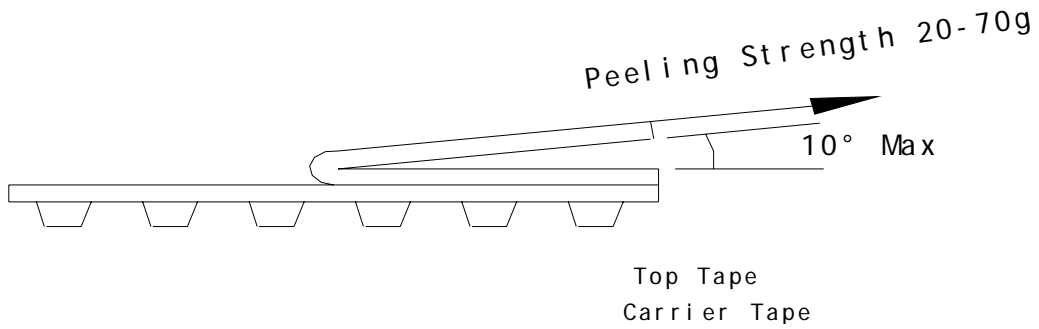

9 EIAJ Monthly Code

2003 / 2005 / 2007 / 2009		2004 / 2006 / 2008 / 2010	
MONTH	CODE	MONTH	CODE
JAN	A	JAN	N
FEB	B	FEB	P
MAR	C	MAR	Q
APR	D	APR	R
MAY	E	MAY	S
JUN	F	JUN	T
JUL	G	JUL	U
AUG	H	AUG	V
SEP	J	SEP	W
OCT	K	OCT	X
NOV	L	NOV	Y
DEC	M	DEC	Z

10 OTHER

10.1 Caution of use

10.1.1 Do not clean or wash the component for it is not hermetically sealed.

10.1.2 Don't be close to fire

10.1.3 Don't apply excess mechanical stress to the component.

10.1.4 Don't bend terminals of the component

10.1.5 This specification mentions the quality of the component as a single unit.

Please insure the component is thoroughly evaluated in your application circuit.

10.2 Notice

10.2.1 Please return one of this specification after your signature of acceptance.

10.2.2 When something gets doubtful with this specifications, we shall jointly work to get an agreement.

