

MECC

CERAMIC RESONATOR SPECIFICATION

PART NO. :

ZTB547P

ELECTRICAL CHARACTERISTICS

- | | |
|---|---------------------------------|
| 1. Resonant Frequency (Fosc) | 547kHz \pm 2kHz |
| 2. Resonant Impedance (Ro) | 40 Ohm max. |
| 3. Temperature Coefficient of Oscillation Frequency | \pm 0.3% max. (-20°C ~ +80°C) |
| 4. Withstanding Voltage | 100VDC for 5 sec. max. |
| 5. Rating Voltage: | |
| D.C. Voltage | 50V |
| A.C. Voltage | 15Vpp |
| 6. Insulation Resistance | 100 MOhm min. @ 10V DC |
| 7. Operating Temperature | -20°C ~ +80°C |
| 8. Storage Temperature | -30°C ~ +80°C |
| 9. Aging Rate (Fosc) | \pm 0.3% max. for 10 years |

MEASUREMENT

Measurement Condition

The reference temperature shall be 25°C \pm 2°C. The measurement shall be performed at the temperature range of 5°C ~ 35°C unless otherwise the result is doubtful.

MEASUREMENT CIRCUIT AND EQUIPMENT

Oscillating frequency shall be measured by the standard test circuit.

Resonant impedance shall be measured by *HP8751A Network Analyzer*.

TEST CIRCUIT

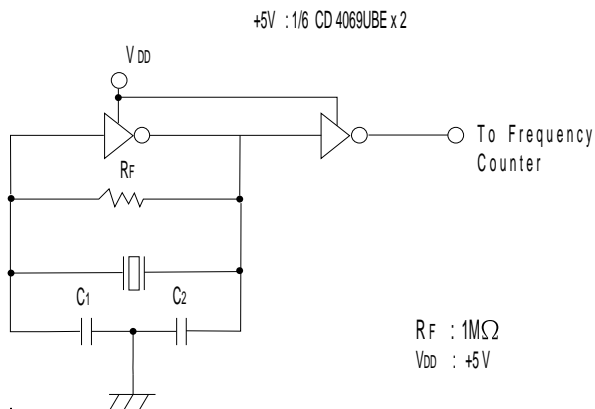

Part Number	Load Capacitance (pF)	
	C1	C2
ZTB190 ~ 249D	330	470
ZTB250 ~ 374D	220	470
ZTB375 ~ 429P	120	470
ZTB430 ~ 509E	100	100
ZTB547P	220	220
ZTB700 ~ 1250J	100	100



Prepared by: Leo Wong
DOC. No: ZTB547P

MECC

CERAMIC RESONATOR SPECIFICATION

MECHANICAL

DIMENSIONS

(Unit = mm)

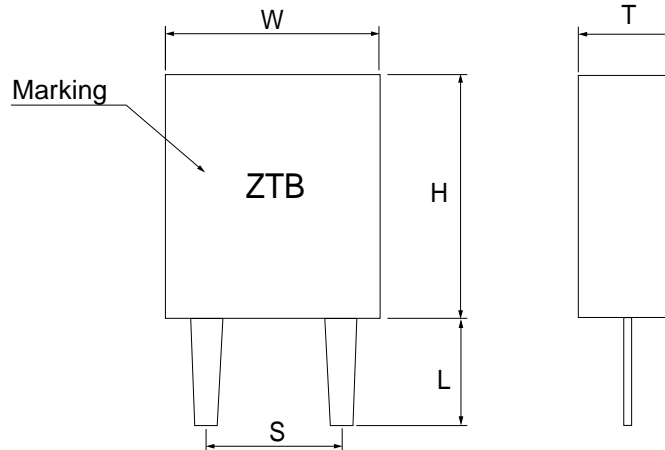

Frequency Range (kHz)	Width W (mm)	Thickness T (mm)	Height H (mm)	Lead Space S (mm)	Lead Length L (mm)
190 ~ 249	13.5	3.8	14.7	10.0	8.0
250 ~ 374	11.0	3.8	12.2	7.7	7.0
375 ~ 400	7.9	3.6	9.3	5.0	7.0
401 ~ 699	7.0	3.5	9.0	5.0	4.0 (6.0)
700 ~ 1250	5.2	2.8	6.8	2.5	3.5 (5.0)

PHYSICAL AND ENVIRONMENTAL CHARACTERISTICS

No.	Item	Condition of Test	Performance Requirements
1	Humidity	Keep the resonator at $40 \pm 2^{\circ}\text{C}$ and 90~95% RH for 96 hours. Then release the resonator into the room condition for 1 hour prior to the measurement.	<i>It shall</i>
2	Vibration	Subject the resonator to vibration for 2 hours each in X, Y and Z axis with the amplitude of 1.5mm, the frequency shall be varied uniformly between the limits of 10~55Hz.	<i>fulfill the</i>
3	Mechanical Shock	Drop the resonator randomly onto a concrete floor from the height of 30cm 3 times.	<i>specifications in Table 1.</i>



Prepared by: Leo Wong
DOC. No: ZTB Series

MIEC

CERAMIC RESONATOR SPECIFICATION

4	High Temperature Exposure	Subject the resonator to $80 \pm 5^{\circ}\text{C}$ for 96 hours. Then release the resonator into the room conditions for 1 hour prior to the measurement.	<i>It shall fulfill the specifications in Table 1.</i>
5	Temperature Cycling	Subject the resonator to -20°C for 30 min. followed by a high temperature of 80°C for 30 min. cycling shall be repeated 5 times with a transfer time of 15 min. at the room condition. Then release the resonator into the room temperature for 1 hour prior to the measurement.	
6	Low Temperature	Subject the resonator to $-20 \pm 5^{\circ}\text{C}$ for 96 ± 4 hours. Then release the resonator into the room conditions for 1 hour prior to the measurement.	
7	Resistance to Solder Heat	Dip the resonator terminals no closer than 2mm into the solder bath at $260 \pm 10^{\circ}\text{C}$ for 3 ± 0.5 sec.	
8	Solderability	Dip the resonator terminals no closer than 2mm into the solder bath at $235 \pm 5^{\circ}\text{C}$ for 3 ± 0.5 sec.	More than 95% of the terminal surface of the resonator shall be covered with fresh solder.
9	<i>Lead Fatigue</i> I) Pulling Test	Weight along with the direction of terminals without any shock 1kg for 10 sec.	The resonator shall show no evidence of damage and shall fulfill all the initial electric characteristics.
	II) Bending Test	Lead shall be subject to withstand against 90 degree bending at its stem. This operation shall be done towards both direction.	

TABLE 1

Item	Specification
Oscillation Frequency Change	$\Delta F / F_{osc} \leq 0.3\%$ max.

REVIEW OF SPECIFICATIONS

When something get doubtful with this specifications, we shall jointly work to get an agreement.



Prepared by: Leo Wong
DOC. No: ZTB Series