

MECC

CERAMIC RESONATOR SPECIFICATION

PART NO. :

ZTB456F18

ELECTRICAL CHARACTERISTICS

| | |
|---|---------------------------------|
| 1. Oscillating Frequency (Fosc) | 19kHz \pm 38Hz |
| 2. Resonant Impedance (Ro) | 30 Ohm max. |
| 3. Temperature Coefficient of Oscillation Frequency | \pm 0.2% max. (-20°C ~ +80°C) |
| 4. Static Capacitance (Co) | 420pF \pm 10% |
| 5. Delta F (Fa - Fr) | 19kHz min. |
| 6. Withstanding Voltage | 50VDC |
| 9. Operating Temperature | -10°C ~ +70°C |
| 10. Storage Temperature | -20°C ~ +80°C |

MEASUREMENT

Measurement Condition

The reference temperature shall be 25°C \pm 2°C. The measurement shall be performed at the temperature range of 5°C ~ 35°C unless otherwise the result is doubtful.

MEASUREMENT CIRCUIT AND EQUIPMENT

Oscillating frequency shall be measured by the standard test circuit as below.

Resonant impedance shall be measured by *HP4194A Impedance Meter*.

Capacitance shall be measured by the Universal Bridge (CCJ - 1C).

TEST CIRCUIT

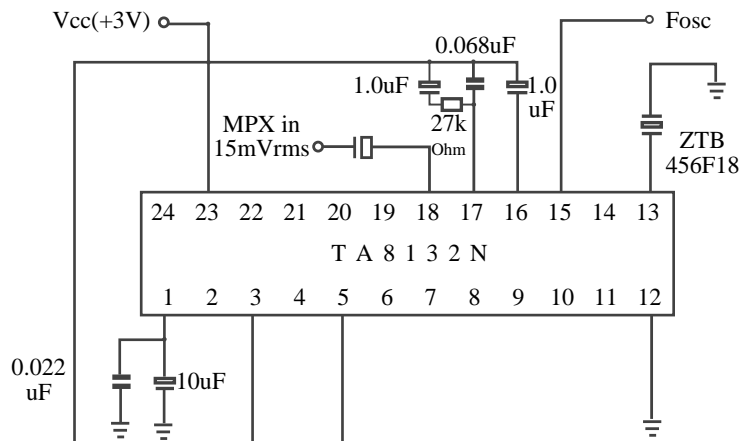

Prepared by: Leo Wong
Checked By: _____
DOC. No: ZTB456F18

MIEC

CERAMIC RESONATOR SPECIFICATION

MECHANICAL

DIMENSIONS

(Unit = mm)

L = 4.0 for Type A
6.0 for Type B

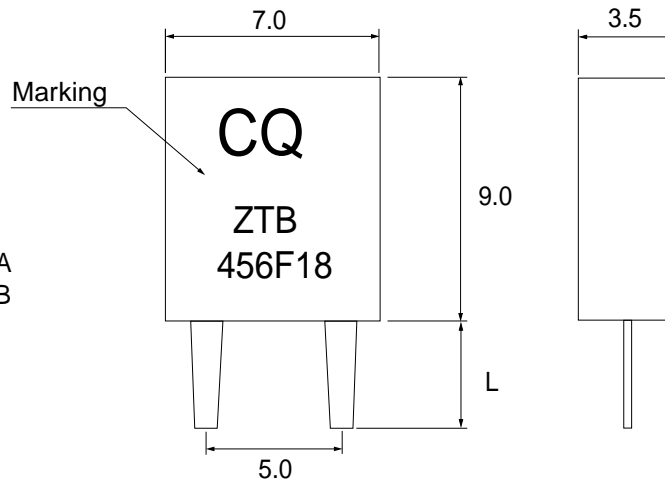

TABLE 1

| Item | Specification |
|------------------------------|--------------------------------------|
| Oscillation Frequency Change | $\Delta F / F_{osc} \leq 0.2\%$ max. |
| Capacitance Change | +/- 10% max. |
| Resonant Impedance | 30 Ohm max. |
| Rated Voltage | 50VDC |

PHYSICAL AND ENVIRONMENTAL CHARACTERISTICS

| No. | Item | Condition of Test | Performance Requirements |
|-----|------------------|---|--|
| 1 | Humidity | Keep the resonator at $40 \pm 2^\circ\text{C}$ and 90% RH for 96 +/- 4 hours. Then release the resonator into the room condition for 1 hour prior to the measurement. | <i>It shall fulfill the specifications in Table 1.</i> |
| 2 | Vibration | Subject the resonator to vibration for 1 hour each in X, Y and Z axis with the amplitude of 1.5mm, the frequency shall be varied uniformly between the limits of 10~55Hz. | |
| 3 | Mechanical Shock | Drop the resonator randomly onto a concrete floor from the height of 100cm 3 times. | |



Prepared by: Leo Wong
Checked By: _____
DOC. No: ZTB456F18

MEC

CERAMIC RESONATOR SPECIFICATION

| | | | |
|---|---|--|--|
| 4 | High Temperature Exposure | Subject the resonator to $80 \pm 5^{\circ}\text{C}$ for 96 hours. Then release the resonator into the room conditions for 1 hour prior to the measurement. | <i>It shall fulfill the specifications in Table 1.</i> |
| 5 | Temperature Cycling | Subject the resonator to -55°C for 30 min. followed by a high temperature of 85°C for 30 min. cycling shall be repeated 5 times with a transfer time of 15 min. at the room condition. Then release the resonator into the room temperature for 1 hour prior to the measurement. | |
| 6 | Low Temperature Exposure | Subject the resonator to $-30 \pm 5^{\circ}\text{C}$ for 96 ± 4 hours. Then release the resonator into the room conditions for 1 hour prior to the measurement. | |
| 7 | Resistance to Solder Heat | Dip the resonator terminals no closer than 1.5mm into the solder bath at $350 \pm 10^{\circ}\text{C}$ for 5 ± 1 sec. | |
| 8 | Solderability | Dip the resonator terminals no closer than 1.5mm into the solder bath at $230 \pm 5^{\circ}\text{C}$ for 5 ± 1 sec. | More than 95% of the terminal surface of the resonator shall be covered with fresh solder. |
| 9 | <i>Lead Fatigue</i> I) Pulling Test | Weight along with the direction of terminals without any shock 3kg. | The resonator shall show no evidence of damage and shall fulfill all the initial electric characteristics. |
| | II) Bending Test | Lead shall be subject to withstand against 90 degree bending at its stem. This operation shall be done towards both direction. | |

REVIEW OF SPECIFICATIONS

When something get doubtful with this specifications, we shall jointly work to get an agreement.



Prepared by: Leo Wong
Checked By: _____
DOC. No: ZTB456F18