

# **MOBICON**

## **Electronic Components**

### **PRODUCT SPECIFICATION**

### **MEC CERAMIC RESONATOR**

### **FREQUENCY COMPONENTS**

**ZTA Series CERAMIC RESONATOR SPECIFICATION**

<b>MOBICON HOLDINGS LTD.</b>		
<b>Prepared By</b>	<b>Sign.</b>	<b>Approved By</b>
Leo Wong		C.H. Wong

**[www.mobicon.com](http://www.mobicon.com)**

# MIEC

## CERAMIC RESONATOR SPECIFICATION

**PART NO. :**

**ZTA 10.0 MT**

### ELECTRICAL CHARACTERISTICS

1. Oscillation Frequency (Fosc)	10.0MHz $\pm$ 0.5%
2. Resonant Impedance (Ro)	- Ohm
3. Temperature Coefficient of Oscillation Frequency	$\pm$ 0.3% max. ( -20°C ~ +80°C)
4. Withstanding Voltage	100VDC for 5 sec. max.
5. Rating Voltage:	
D.C.	6V max.
A.C.	15Vpp max.
6. Insulation Resistance	100 MOhm min. @ 10V DC
7. Operating Temperature	-20°C ~ +80°C
8. Storage Temperature	-30°C ~ +85°C

### MEASUREMENT

#### Measurement Condition

The reference temperature shall be 25°C  $\pm$  2°C. The measurement shall be performed at the temperature range of 5°C ~ 35°C unless otherwise the result is doubtful.

### MEASUREMENT CIRCUIT AND EQUIPMENT

Oscillating frequency shall be measured by the standard test circuit.

Resonant impedance shall be measured by *HP8751A Network Analyzer*.

#### Mechanical Dimensions (Unit = mm)

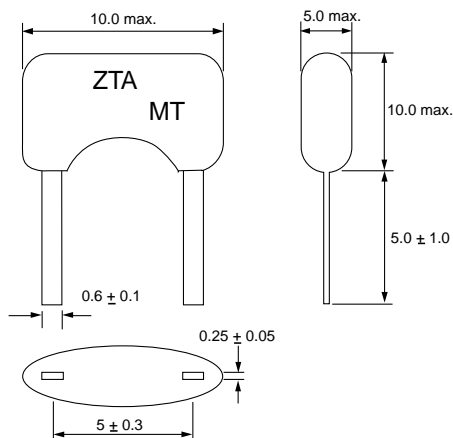

#### Test Circuit ( C<sub>1</sub>, C<sub>2</sub> = 30pF~33pF )

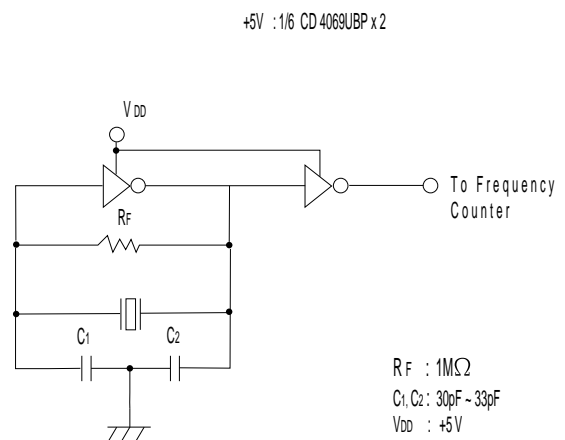

Prepared By: Leo Wong

DOC. No: ZTA10.0MT

# MIEC

## CERAMIC RESONATOR SPECIFICATION

### PHYSICAL AND ENVIRONMENTAL CHARACTERISTICS

No.	Item	Condition of Test	Performance Requirements
1	Humidity	Keep the resonator at $40 \pm 2^{\circ}\text{C}$ and 90~95% RH for $96 \pm 4$ hours. Then release the resonator into the room condition for 1 hour prior to the measurement.	<i>It</i>
2	Vibration	Subject the resonator to vibration for 2 hours each in X, Y and Z axis with the amplitude of 1.5mm, the frequency shall be varied uniformly between the limits of 10~55Hz.	<i>shall</i>
3	Mechanical Shock	Drop the resonator randomly onto a concrete floor from the height of 100cm 3 times.	<i>fulfill</i>
4	High Temperature Exposure	Subject the resonator to $80 \pm 5^{\circ}\text{C}$ for 96 hours. Then release the resonator into the room conditions for 1 hour prior to the measurement.	<i>the</i>
5	Temperature Cycling	Subject the resonator to $-20^{\circ}\text{C}$ for 30 min. followed by a high temperature of $80^{\circ}\text{C}$ for 30 min. cycling shall be repeated 5 times with a transfer time of 15 sec. at the room condition. Then release the resonator into the room temperature for 1 hour prior to the measurement.	<i>specifications</i>
6	Low Temperature	Subject the resonator to $-20 \pm 5^{\circ}\text{C}$ for $96 \pm 4$ hours. Then release the resonator into the room conditions for 1 hour prior to the measurement.	<i>in Table 1..</i>
7	Resistance to Solder Heat	Dip the resonator terminals no closer than 2mm into the solder bath at $260 \pm 5^{\circ}\text{C}$ for $10 \pm 1$ sec.	

# MIEC

## CERAMIC RESONATOR SPECIFICATION

8	Solderability	Dip the resonator terminals no closer than 2mm into the solder bath at $235 \pm 5^{\circ}\text{C}$ for $2 \pm 0.5$ sec.	More than 95% of the terminal surface of the resonator shall be covered with fresh solder.
9	<i>Lead Fatigue</i> I ) Pulling Test	Weight along with the direction of terminals without any shock 1kg for $10 \pm 1$ sec.	The resonator shall show no evidence of damage and shall fulfill all the initial electric characteristics.
	II ) Bending Test	Lead shall be subject to withstand against 90 degree bending at its stem. This operation shall be done towards both direction.	

**TABLE 1**

Item	Specification
Oscillation Frequency Change	$\Delta F / F_{osc} \leq 0.5\%$ max.

### REVIEW OF SPECIFICATIONS

- 1) When something get doubtful with this specifications, we shall jointly work to get an agreement.
- 2) This specification limits the quality of the components as a single unit. Please insure the component is thoroughly evaluated in your application circuit.
- 3) Please do not use this component in any application that deviates from its intended use as noted within the specification. It may cause any mishaps.
- 4) Please return one of this specification after your signature of acceptance. In case of no return within 3 months from submission date. This specification should be treated as accepted.



Prepared By: Leo Wong  
DOC. No: ZTA-MT