

MOBICON

Electronic Components

PRODUCT SPECIFICATION

MEC

Ceramic Resonator

SPECIFICATION

This specifications is subject to change without notice.

MOBICON HOLDINGS LTD.		
Prepared By	Sign.	Approved By
Kiko Chan		C.H. Wong

Reprinting and copying of this specifications without prior written permission from MOBICON HOLDINGS LTD are not permitted.

MEC

PART NO. :

ZTACC8.00MG-EN

ELECTRICAL CHARACTERISTICS

1 SCOPE

This specification shall cover the characteristics of the ceramic resonator with the type ZTACC8.00MG.

2 PART NO.

PART NUMBER	CUSTOMER PART NO	SPECIFICATION NO
ZTACC8.00MG		

3 OUTLINE DRAWING AND DIMENSIONS

3.1 Appearance: No visible damage and dirt.

3.2 Except the chip(ceramic element, ceramic base, capacitance slice), the materials don't contain lead.

3.3 Dimensions

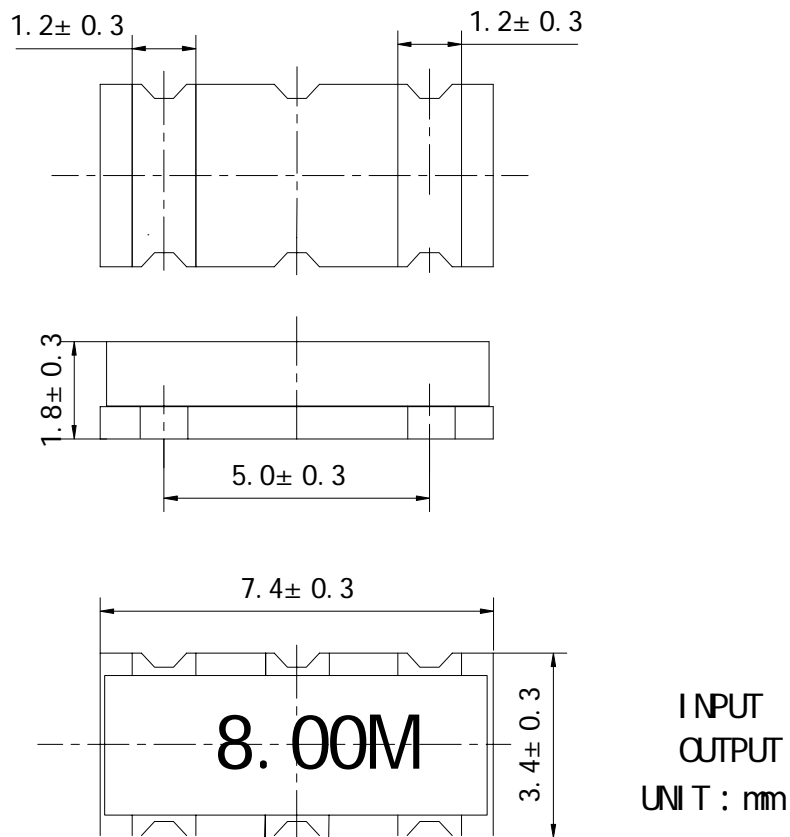

MEC

4 RATING AND ELECTRICAL SPECIFICATIONS

4.1 RATING

Items	Content
Withstanding Voltage (V)	50 (DC , 1min)
Insulation Resistance Ri, (M) min.	100 (100V , 1min)
Operating Temperature Range ()	-20 ~ +80
Storage Temperature Range ()	-55 ~ +85

4.2 ELECTRICAL SPECIFICATIONS

Oscillation Frequency Fosc (MHz)	8.000
Frequency Accuracy (%)	± 0.5
Resonant Impedance Ro (Ω) max.	30
Temperature Coefficient of Oscillation Frequency (%) max.	± 0.3 (Oscillation Frequency drift , -20 ~ +80)
Rating Voltage UR (V) max.	6V DC
	15V p-p
Aging Rate (%) max.	± 0.3 (For Ten Years)

5 MEASUREMENT

5.1 Measurement Conditions

Parts shall be measured under a condition (Temp. : 20 ±15 , Humidity : 65%±20% R.H.) unless the standard condition(Temp. : 25 ±3 , Humidity : 65%±5% R.H.) is regulated to measure.

5.2 Test Circuit

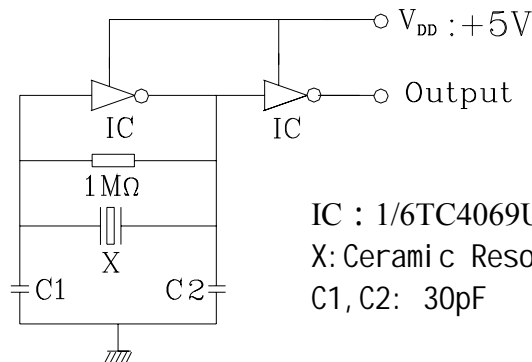

IC : 1/6TC4069UBP×2
 X: Ceramic Resonator
 C1, C2: 30pF

MIEC

6 PHYSICAL AND ENVIRONMENTAL CHARACTERISTICS

No	Item	Condition of Test	Performance Requirements	
6.1	Humidity	Keep the resonator at 40 ± 2 and 90%-95% RH for $96h \pm 4h$. Then Release the resonator into the room Condition for 1h prior to the Measurement.	It shall fulfill the specifications in Table 1.	
6.2	Vibration	Subject the resonator to vibration for 2h each in x、 y and z axis With the amplitude of 1.5mm, the frequency shall be varied uniformly between the limits of 10 Hz—55Hz.	It shall fulfill the specifications in Table 1.	
6.3	Mechanical Shock	Drop the resonator randomly onto a wooden floor from the height of 100cm 3 times.	It shall fulfill the specifications in Table 1.	
6.4	Soldering Test	Passed through the re-flow oven under the following condition and left at room temperature for 1h before measurement.	It shall fulfill the specifications in Table 1.	
		Temperature at the surface of the substrate		Time
		Preheat 150 ± 5		$60s \pm 10 s$
		Peak 260 ± 5		$10s \pm 3 s$
6.5	Solder Ability	Dipped in 245 ± 5 solder bath for $3s \pm 0.5 s$ with rosin flux (25wt% ethanol solution.)	The terminals shall be at least 95% covered by solder.	
6.6	High Temperature Exposure	Subject the resonator to 80 ± 5 for 96s, then release the resonator into the room conditions for 1h prior to the measurement.	It shall fulfill the specifications in Table 1.	
6.7	Low Temperature Exposure	Subject the resonator to -20 ± 5 for 96h, then release the resonator into the room conditions for 1h prior to the measurement.	It shall fulfill the specifications in Table 1.	

(To be continued)

MIEC

6 PHYSICAL AND ENVIRONMENTAL CHARACTERISTICS

No	Item	Condition of Test	Performance Requirements
6.8	Temperature Cycling	Subject the resonator to -40 for 30 min. followed by a high temperature of 85 for 30 min. Cycling shall be repeated 5 times with a transfer time of 15s. At the room temperature for 1h prior to the measurement.	It shall fulfill the specifications in Table 1.
6.9	Board Bending	Mount a glass-epoxy board (Width=40mm,thickness=1.6mm),then bend it to 1mm displacement and keep it for 5s. (See the following figure) 	Mechanical damage such as breaks shall not occur.

Table 1

Item	Specification after test
Oscillation Frequency Change F_{osc}/F_{osc} (%) max	±0.3
Resonant Impedance () max	40
The limits in the above table are referenced to the initial measurements.	

MEC

7 RECOMMENDED LAND PATTERN AND REFLOW SOLDERING STANDARD CONDITIONS

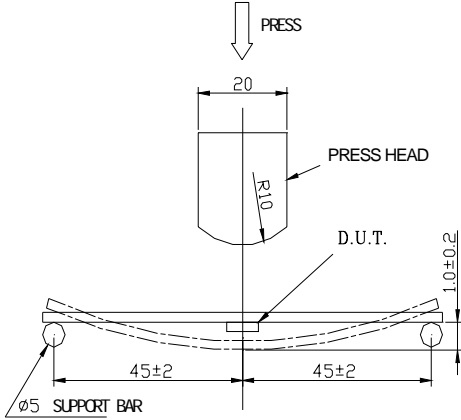
7.1 Recommended land pattern

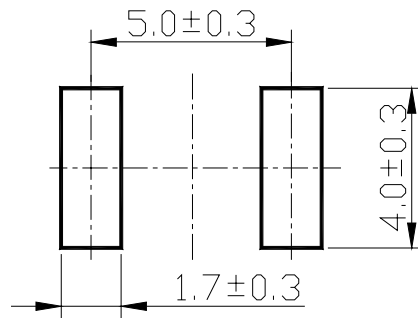

7.2 Recommended reflow soldering standard conditions

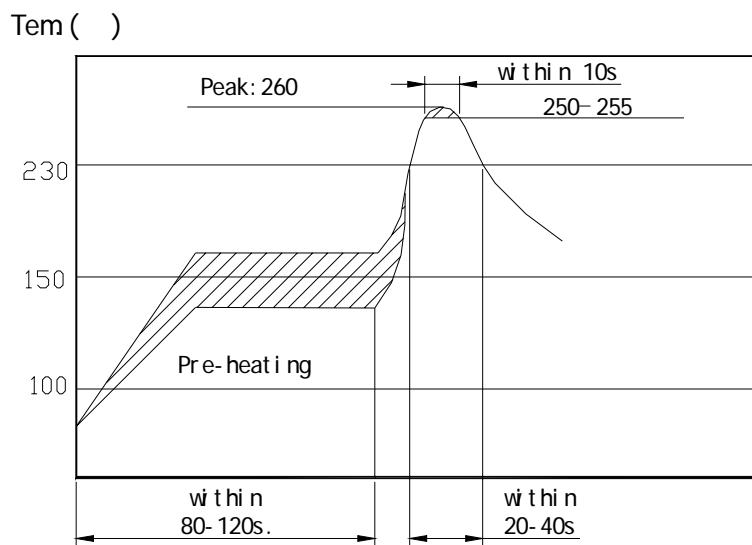

8 PACKAGE

To protect the products in storage and transportation, it is necessary to pack them (outer and inner package). On paper pack, the following requirements are requested.

8.1 Dimensions and Mark

At the end of package, the warning (moisture proof, upward put) should be stick to it.

MEC

Dimensions and Mark (see below)

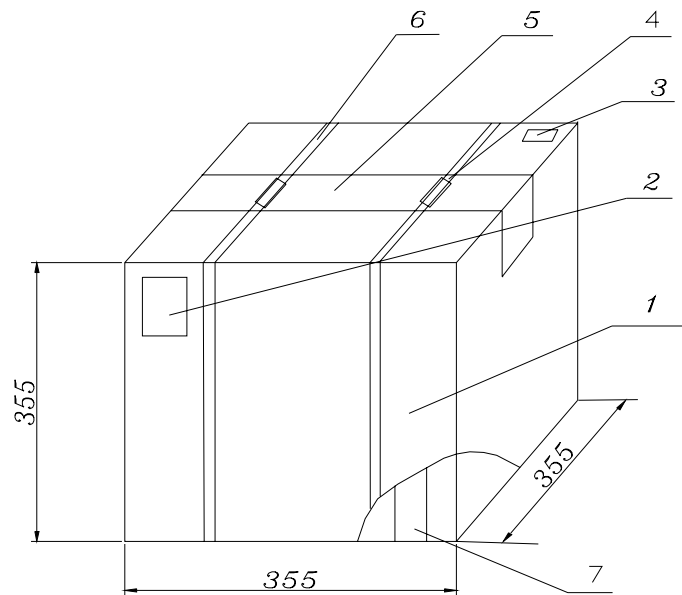

NO.	Name	Quantity	Notes
1	Package	1	
2	Certificate of approval	1	
3	Label	1	
4	Tying	2	
5	Adhesive tape	1.2m	
6	Belt	2.9m	
7	Inner Box	10	

8.2 Section of package

Package is made of corrugated paper with thickness of 0.8cm. Package has 10 inner boxes, each box has 1 reel (each reel for plastic bag)

8.3 Quantity of package

Per plastic reel 4000 pieces of piezoelectric ceramic part

Per inner box 1 reel

Per package 10 inner boxes

(40000 pieces of piezoelectric ceramic part)

MEC

8.4 Inner Packing Dimensions

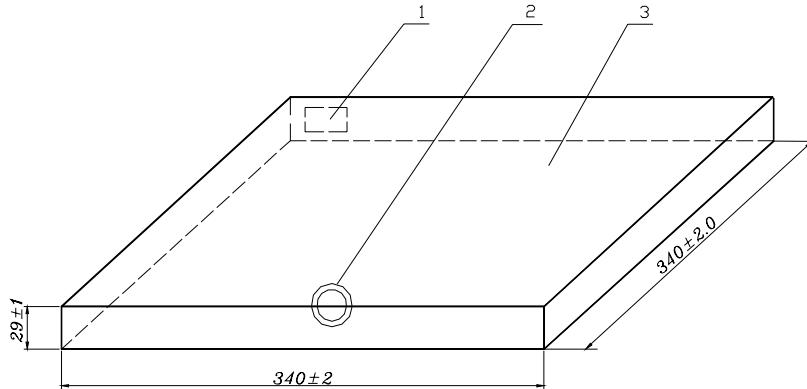

1	Label
2	QC Label
3	Inner Box

Pars shall be packed in box with hold down tape upside. Part No., qty & lot No.

8.5 Reel

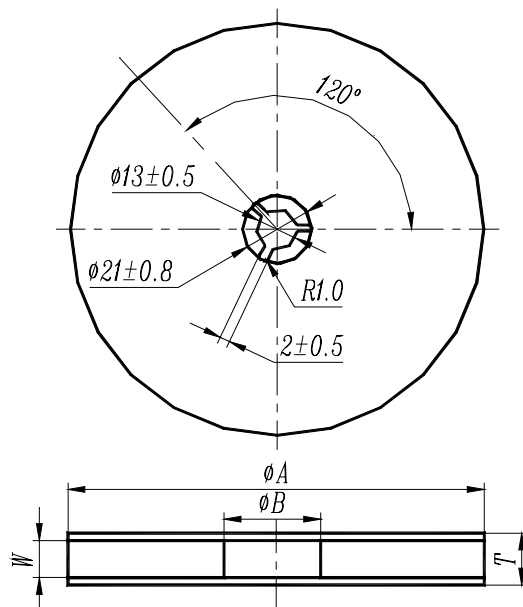

Dimensions

Unit : mm

MEC

A	B	W	T	Pieces per reel	Carrier tape size
330 ± 3	80min	16.4min	22.4max	4000typ.	16

8.6 Taping Dimensions

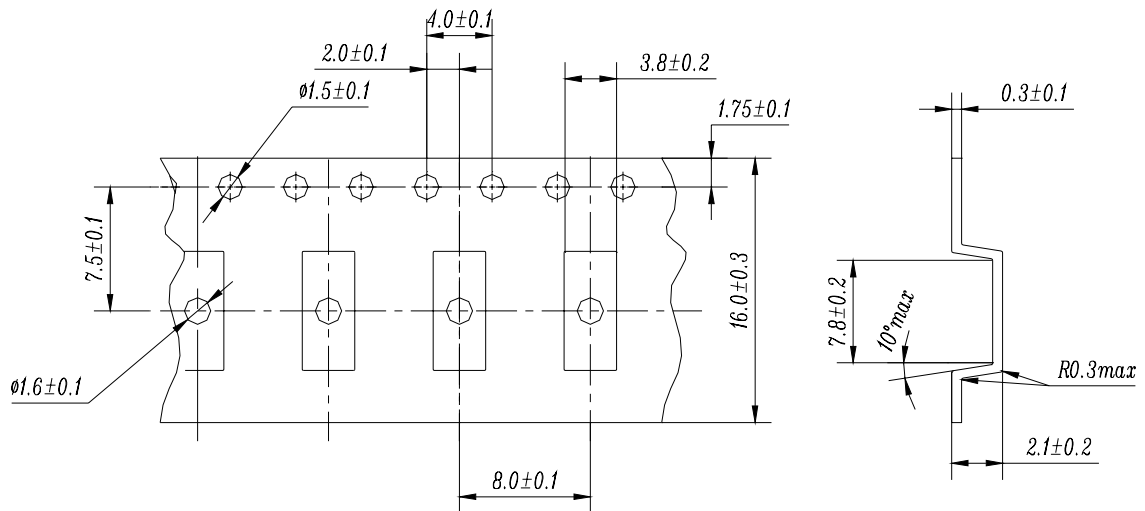

8.7 Packing Method Sketch Map

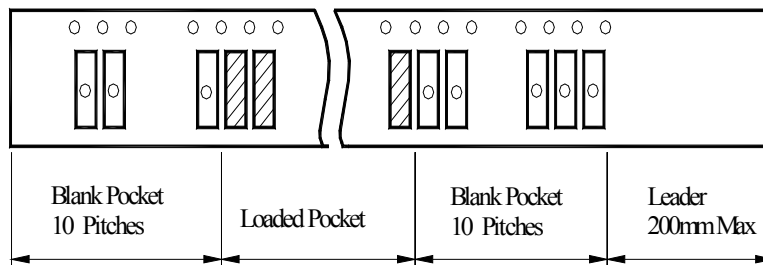

8.8 Test Condition Of Peeling Strength

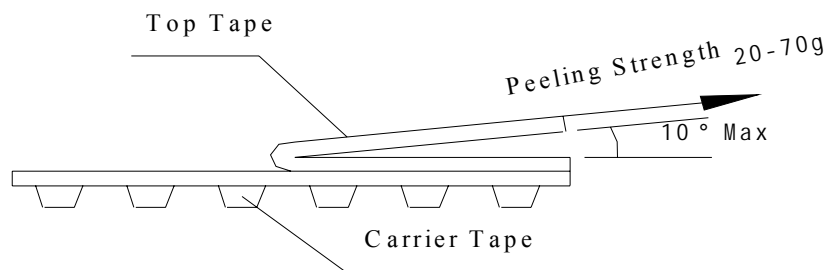

MEC

9 OTHER

9.1 Caution of use

9.1.1 Do not use this product with bend. Please don't apply excess mechanical stress to the component and terminals at soldering.

9.1.2 The component may be damaged when an excess stress will be applied.

9.1.3 This specification mentions the quality of the component as a single unit. Please insure the component is thoroughly evaluated in your application circuit.

9.2 Notice

9.2.1 Please return one of this specification after your signature of acceptance.

9.2.2 When something gets doubtful with this specifications, we shall jointly work to get an agreement.

MIEC

REVIEW OF SPECIFICATIONS

- 1) When something get doubtful with this specifications, we shall jointly work to get an agreement.
- 2) This specification limits the quality of the components as a single unit. Please insure the component is thoroughly evaluated in your application circuit.
- 3) Please do not use this component in any application that deviates from its intended use as noted within the specification. It may cause any mishaps.
- 4) Please return one of this specification after your signature of acceptance. In case of no return within 3 months from submission date. This specification should be treated as accepted.

When using our products, the following precautions should be taken.

- (1) Safety designing of apparatus or a system allowing for failures of electronic components used in the system
In general, failures will occur in electronic components at a certain probability. MOBICON HOLDINGS LTD makes every effort to improve the quality and reliability of electronic component products. However, it is impossible to completely eliminate the probability of failures. Therefore, when using MOBICON HOLDINGS LTD electronic component products, systems should be carefully designed to ensure redundancy in the event of an accident which would result in injury or death, fire, or social damage, to ensure the prevention of the spread of fire, and the prevention of faulty operation.
- (2) Quality Level of various kinds of parts, and equipment in which the parts can be utilized
Electronic components have a standard quality level unless otherwise specified.
- (3) This specifications is subject to change without notice.
The contents of this specifications are based on data which is correct as of 2002, and they may be changed without notice. If our products are used for mass-production design, please enquire consult with a member of our company's sales staff by way of precaution.
- (4) Reprinting and copying of this specifications without prior written permission from MOBICON HOLDINGS LTD are not permitted.
- (5) Industrial Property Problems
In the event any problems associated with industrial property of a third party arising as a result of the use of our products. MOBICON HOLDINGS LTD assumes no responsibility for problems other than problems directly associated with the constitution and manufacturing method of the products.