

MOBICON

Electronic Components

PRODUCT SPECIFICATION

MEC SMD OSCILLATOR

FREQUENCY COMPONENTS

SMD-MO12A SMD OSCILLATOR SPECIFICATION

MOBICON HOLDINGS LTD.		
Prepared by	Sign.	Approved by
Leo Wong		

www.mobicon.com

MEC

CRYSTAL OSCILLATOR SPECIFICATION

FEATURE:

This crystal oscillator employs hybrid IC, crystal technology and designed to be used in CMOS logic family. This model has excellent duty cycle, great fan out capability, low power consumption, which is useful for a variety of application.

PART NO. :

SMD - MO 25A

ELECTRICAL CHARACTERISTICS

1. Nominal Frequency	11.2896 MHz
2. Holder Type	SMD (4 Pins)
3. Frequency Stability	± 100 ppm
4. Input Current	30 mA
5. Operating Voltage	3.3V _{DC} +/- 10%
6. "0" Level (Low Voltage)	+ 0.3V (90% V _{DD}) max.
7. "1" Level (High Voltage)	- 3.0V (10% V _{DD}) max.
8. Rise and Fall Time	5ns max.
9. Operating Temperature	0°C ~ +70°C
10. Storage Temperature	-55°C ~ +125°C
11. Duty Cycle	40 ~ 60%
12. Output Load	15pF

OUTPUT WAVEFORM

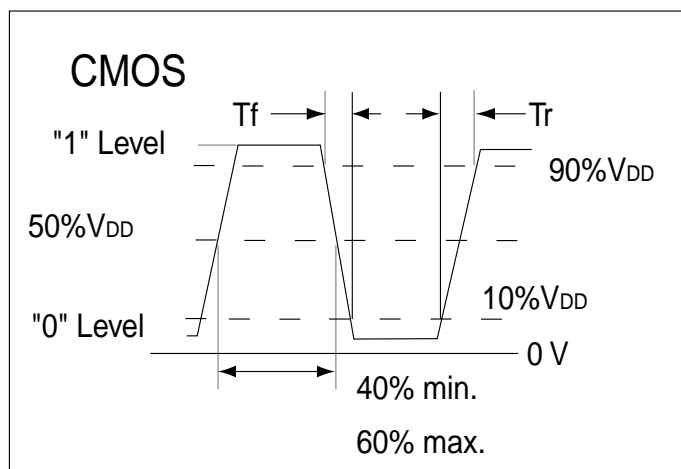

MARKING

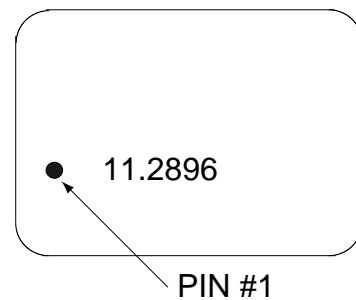

MIEC

CRYSTAL OSCILLATOR SPECIFICATION

TEST CIRCUIT

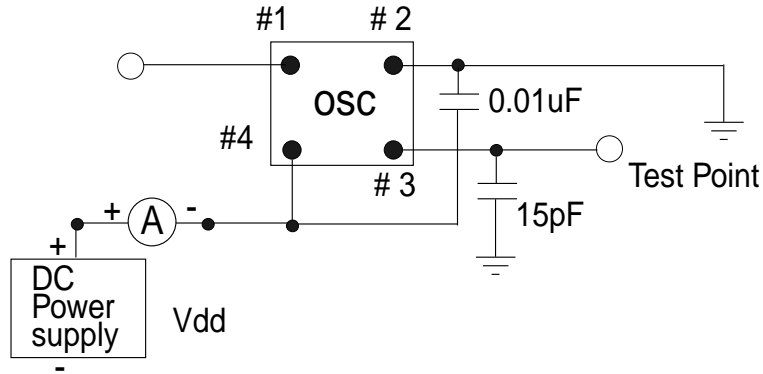

Mechanical Dimensions (Unit = mm)

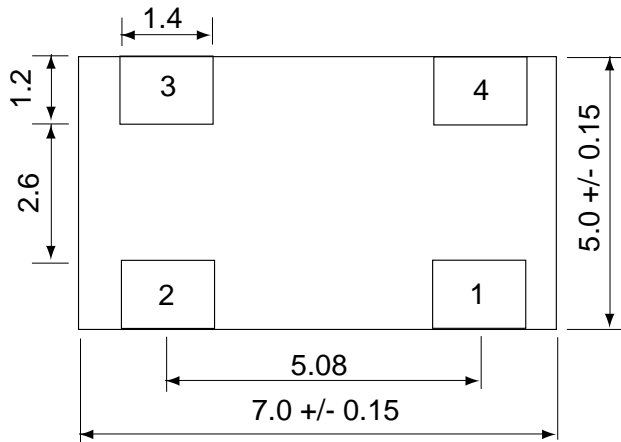

Pin: Connection

- 1: Control Top
- 2: GND
- 3: Output
- 4: Vdd

REVIEW OF SPECIFICATIONS

- 1) When something get doubtful with this specifications, we shall jointly work to get an agreement.
- 2) This specification limits the quality of the components as a single unit. Please insure the component is thoroughly evaluated in your application circuit.
- 3) Please do not use this component in any application that deviates from its intended use as noted within the specification. It may cause any mishaps.
- 4) Please return one of this specification after your signature of acceptance. In case of no return within 3 months from submission date. This specification should be treated as accepted.

