



CRYSTAL

SMD49S-8M1630F

This specifications is subject to change without notice.
Reprinting and copying of this specifications without prior written
permission from MOBICON HOLDINGS LTD are not permitted.

www.mobicon.com

7/F., New Trend Centre, 704 Prince Edward Road East, San Po Kong, Kowloon, Hong Kong.

■ ELECTRICAL SPECIFICATIONS

Standard atmospheric conditions

Unless otherwise specified. The standard range of atmospheric conditions for making measurement and tests are as follow:

- Ambient temperature : 25 ± 5
- Relative humidity: 40%~70%

If there is no doubt the results, measurement shall be made within the following limits:

- Ambient temperature : 25 ± 1
- Relative humidity: 40%~70%

Measure equipment

Electrical characteristics measured by S&A 250B or equivalent.

Crystal cutting type

The crystal is using AT CUT (thickness shear mode)

	Parameters	SYM	Electrical spec.	UNITS	Notes
1	Nominal Frequency	FL	8.000	MHz	-
2	Oscillation Mode	-	FUND	-	-
3	Load Capacitance	CL	16	pF	-
4	Frequency Tolerance	-	± 30	ppm	at 25 ± 3
5	Frequency Tolerance	-	± 30	ppm	Over Operating Temp. Range (Reference 25)
6	Operating Temperature	-	-20~+70		-
7	Aging	-	± 5	ppm	1st Year
8	Drive Level	DL	100	μ W	-
9	Effective Resistance Rr	Rr	60 max		-
10	Shunt Capacitance C0	C0	7max	pF	-
11	Motional Capacitance C1	C1	-	fF	-
12	Spurious Response	SPDB	-.	dB	
13	Insulation Resistance	-	500	M	at DC 100V
14	Storage Temperature Range	-	-55~+125		-
15	Others				



■ **DIMENSION**

1. Crystal enclosure seal : resistance weld
2. Crystal enclosure medium : Nitrogen

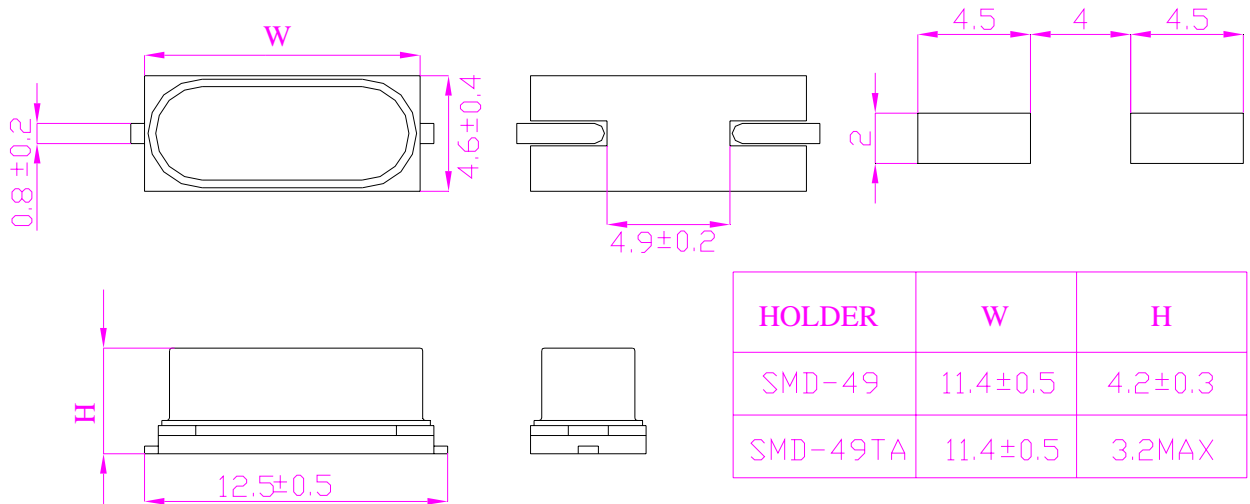

■ **MARKING**

M8.000E8D

■ **SHELF LIFE & STORAGE CONDITIONS**

No shipment is allowed by manufactured over 1 year .

Storage Conditions:

Temp.	Humidity
25 ± 3	40~60%

■ **SUGGESTED REFLOW PROFILE**

Total time : 200sec.Max.

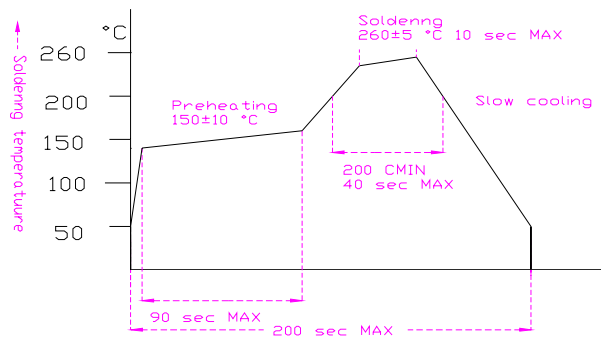

■ STRUCTURE ILLUSTRATION

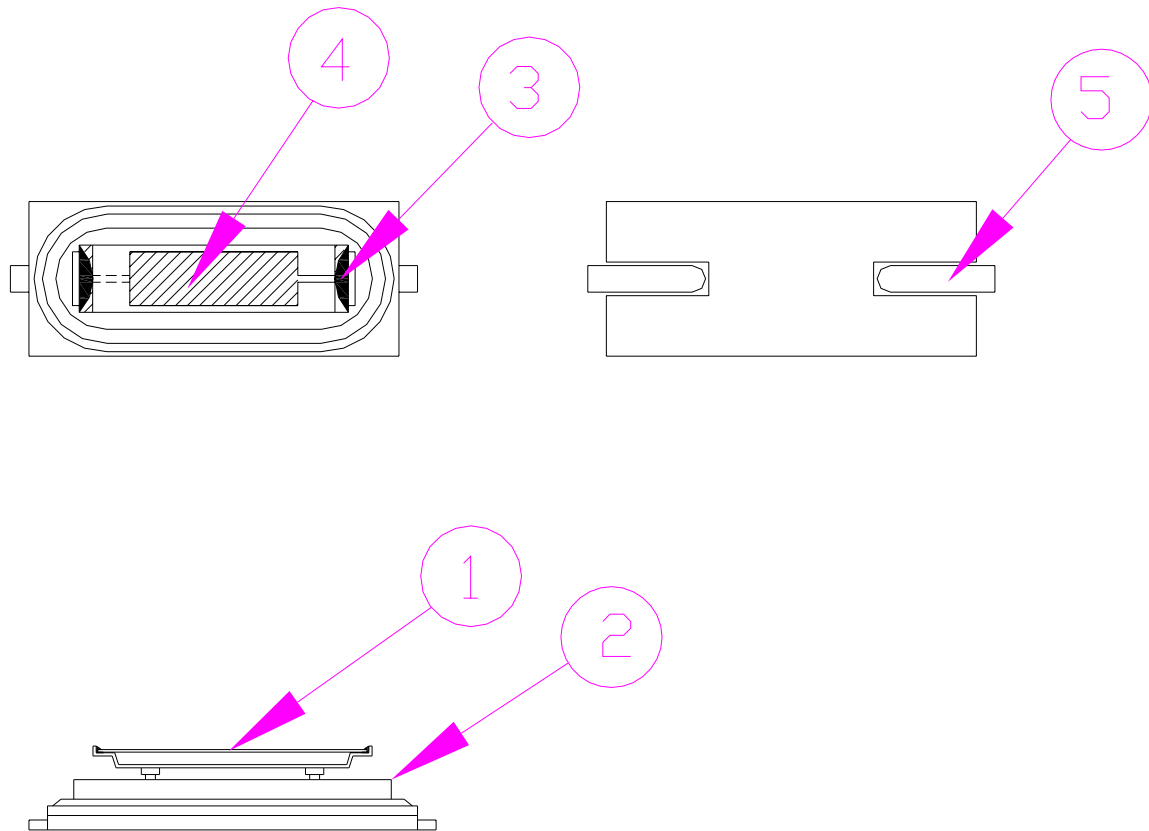

No	COMPONENTS	MATERIALS	QTY	FINISH/SPECIFICATIONS
1	CRYSTAL BLANK	SiO ₂	1	-
2	BASE	SPCC-SD	1	-
3	CONDUCTIVE ADHESIVE	Ag + Resin	2	-
4	ELECTRODE	Ag	2	-
5	ELECTRODE	Ag + Cr	2	-



- **PACKING: (EIA-481-2)** — Shear strength between cover and carrier tape should be 30-100g.
 - Carrier tape should be folded over three times with no break at all.

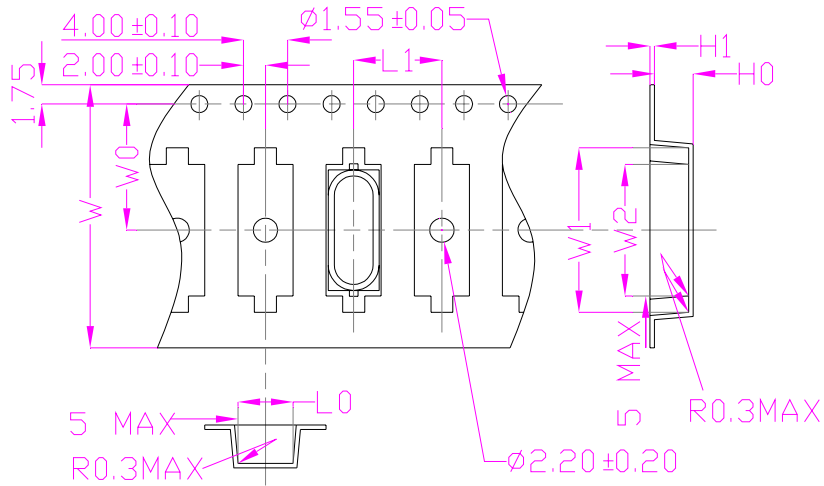

Specification	Symbol	Dimension Tolerance (mm)							
	W	W0	W1	W2	L0	L1	H0	H1	
49-SMD		24 ± 0.3	11.5 ± 0.1	15 ± 0.1	12 ± 0.1	5.0 ± 0.1	8.0/12.0 ± 0.1	0.4 ± 0.05	4.25/3.5 ± 0.2

REMARK:

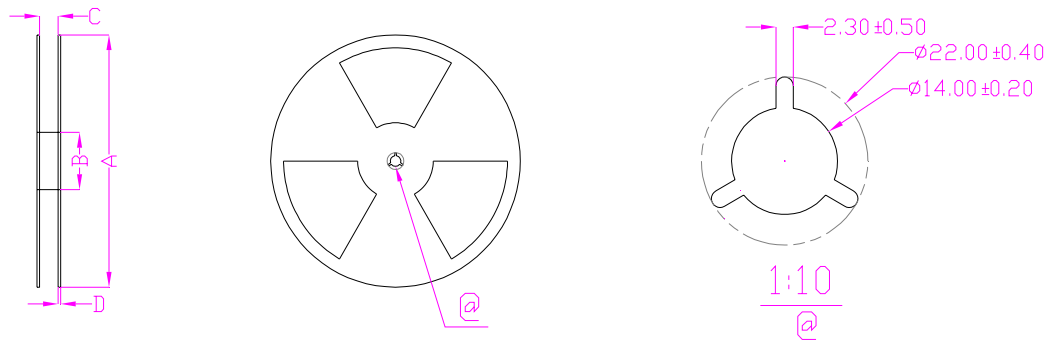
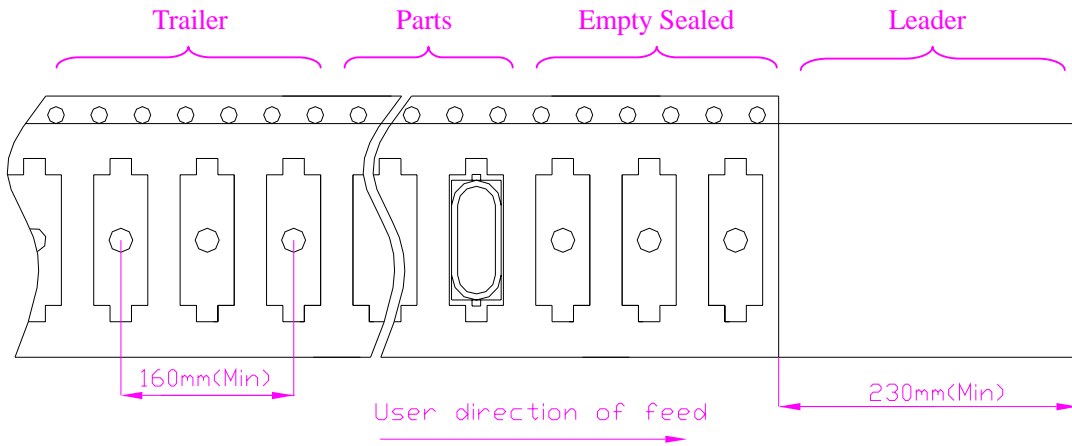

Specification	Symbol	Dimension Tolerance (mm)			
	A	B	C	D	
49-SMD		330 ± 2.0	100 ± 1.0	24.5 ± 1.0	2.4 ± 0.2

Unit : mm

Standard Reel Quantity is 1,000 pcs per reel.



■ PACKING FOR PB FREE PARTS:

1 . INNER BOX :(Unit : mm)

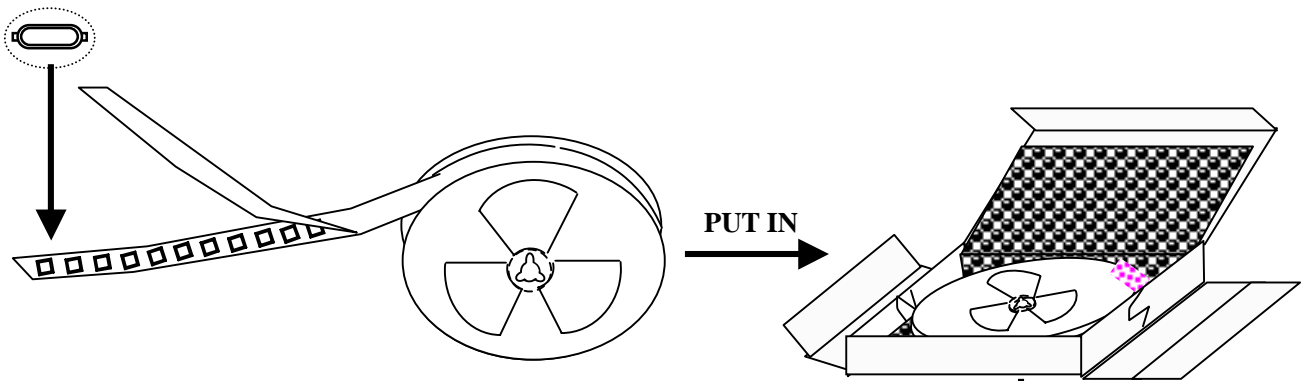

2 . LOGO STICKER (CARTON and INNER BOX) :(Unit : mm)

Dimensions(+/-10)				
No	w	l	h	Q'ty
1.	335	335	35	1K

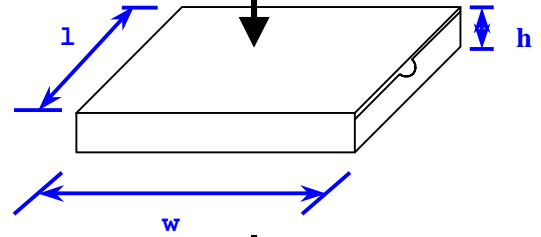

Put in stuff between space,
1000pcs/box*5box=5000pcs/carton

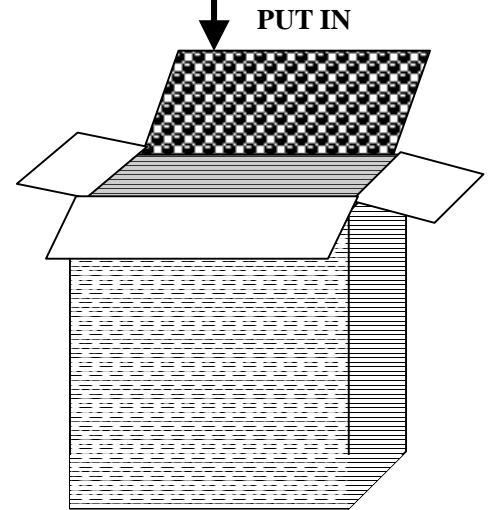

Dimensions(+/-10)				
No	W	L	H	Q'ty
1.	390	340	29	5K

Tie up the carton with 2 packthreads.

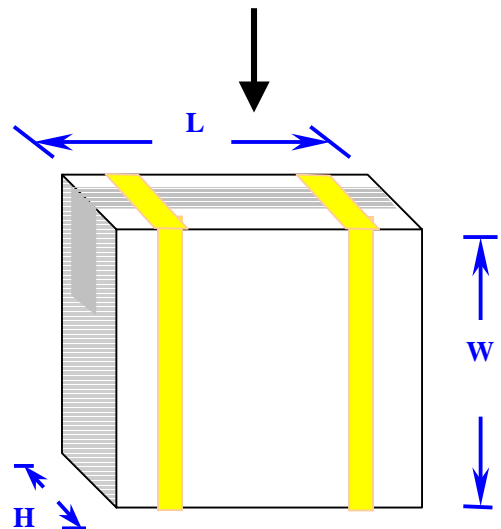

MEC

■ RELIABILITY SPECIFICATIONS

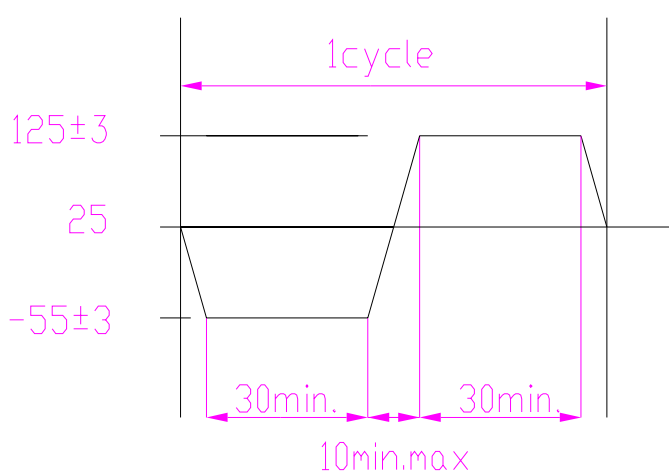
NO	Test Item	Test Methods	Ref.Doc
1	Drop test	50 cm height, fall freely onto stainless plate 3times.	-
2	Mechanical Shock	Device are shocked to half sine wave (1000G) three mutually pendicular axes each 3 times.0.5sec.duration time.	-
3	Vibration	Frequency range 10~2000Hz Amplitude 1.52mm Sweep time 20 minute Pendicular axes each test time 4 hours (Total test time 12 hours)	-
4	Solderability	Temperature 255 ± 5 Immersing depth 0.5mm minimum Immersion time 10 ± 0.5seconds Flux Rosin resin methyl alcohol Solvent (1:4)	-
5	Resistance To Soldering Heat	Pre-heat temperature 125 Pre-heat time 60~120sec. Test temperature 260 ± 5 Test time 5 ± 1sec.	-
6	High Temp. Storage	+125 ± 2 for 1000 ± 12hours	-
7	Low temp. Storage	-40 ± 2 for 1000 ± 12hours	
8	Thermal Cycles	Total 100 cycles of the following temperature cycle 	-



环境管理物质使用规范

Specification of the environment-related substances

范围 Range	产品 Products	包材 Packing Material	Test Method
禁限物质 Banned Substances	最高含量 Maximum concentration ppm(mg/kg)	最高含量 Maximum concentration ppm(mg/kg)	
1. 镉及镉化合物 Cadmium and cadmium compounds	5	5	ICP-AES as per EN1122, method B2001 or other acid digestion. ICP-AES after as per EPA 3050B or other acid digestion. ICP-AES after as per EPA 3052 or other acid digestion. As per US EPA 7196A and US EPA 3060A. With reference to USEPA 3540 or USEPA3550. Analysis was performed by LPLC/DAD, LC/MS or GC/MS. (prohibited by 2002/95/EC (RoHS),83/261/EEC, and76/769/EEC) With reference to USEPA3540or USEPA3550. Analysis was performed by HPLC/DAD LC/MS or GC/MS.(prohibited by 2002/95/EC(RoHS), 83/264/EEC, and 76/769/EEC)
2. 铅及铅化合物 Lead and lead compounds	40	100	
3. 汞及汞化合物 Mercury and mercury compounds	5	5	
4. 六价铬化合物 Hexavalent-Chromium VI (Cr ⁺⁶)	10	10	
5. 聚溴联苯 PBB Polybrominated biphenyls	5	5	
6. 聚溴二苯醚 PBDE Polybrominated diphenyl ethers	5	5	
7. 多氯联苯 (PCB) Polychlorinated biphenyl	5	5	
8. 多氯化萘 (PCN) Polychlorinated naphthalene	5	5	
9. 氯代烷烃 (CP) Chlorinated paraffin	5	5	
10. 其他有机氯化物 Other chlorinated organic compounds	5	5	
11. 其他有机溴化合物 Other brominated organic compounds	5	5	
12. 有机锡化合物 (三丁基锡化合物, 三苯基锡化合物) Organic tin compounds (Tributyl tin category & Triphenyl tin category)	5	5	
13. 石棉 Asbestos	5	5	
14. 偶氮化合物 Azo compounds	5	5	
15. 甲醛 Formaldehyde	5	5	
16. 聚氯乙烯(PVC)以及聚氯乙烯混合物 Polyvinyl chloride (PVC) and PVC blends	No detect	No detect	
17. 包装材料中重金属(汞、镉、六价铬、铅、PBB、PBDE)之总量 Heavy metals (mercury, cadmium, lead, Cr ⁺⁶ ,PBB and PBDE) in packing materials	N/A	<100	

Lead Free Products are “Directive 2002/95/EC of The European Parliament of 27 January 2003 on the restriction of certain hazardous substances (RoHS) in electrical and electronic equipment” and Sony SS-00259 Compliant.

