



CRYSTAL

SPECIFICATION OF CRYSTAL

This specifications is subject to change without notice.
Reprinting and copying of this specifications without prior written
permission from MOBICON HOLDINGS LTD are not permitted.

www.mobicon.com

7/F., New Trend Centre, 704 Prince Edward Road East, San Po Kong, Kowloon, Hong Kong.

MEC

■ ELECTRICAL SPECIFICATIONS

Standard atmospheric conditions

Unless otherwise specified. The standard range of atmospheric conditions for making measurement and tests are as follow:

Ambient temperature : $25 \pm 5^{\circ}\text{C}$

Relative humidity: 40%~70%

If there is no doubt the results, measurement shall be made within the following limits:

Ambient temperature : $25 \pm 1^{\circ}\text{C}$

Relative humidity: 40%~70%

Measure equipment

Electrical characteristics measured by S&A 250B or equivalent.

Crystal cutting type

The crystal is using AT CUT (thickness shear mode)

	Parameters	SYM	Electrical spec.	UNITS	Notes
1	Nominal Frequency	FL	22.118400	MHz	-
2	Oscillation Mode	-	Fund	-	-
3	Load Capacitance	CL	18	pF	-
4	Frequency Tolerance	-	± 20	ppm	MAX
5	Frequency Tolerance	-	± 30	ppm	Over Operating Temp. Range (Reference 25°C)
6	Operating Temperature	-	$-20 \sim +70$	$^{\circ}\text{C}$	-
7	Aging	-	± 1	ppm	1st Year
8	Drive Level	DL	100	μW	-
9	Effective Resistance Rr	Rr	80	Ω	MAX
10	Shunt Capacitance C0	C0	5	pF	-
11	Motional Capacitance C1	C1	-	fF	-
12	Spurious Response	SPDB	-	dB	The spec. is $<-3\text{dB}(\text{Max.})$ Within $\pm 5000\text{ppm}$ of nominal Freq. unless otherwise specified.
13	Insulation Resistance	-	500	$\text{M}\Omega$	at DC 100V
14	Storage Temperature Range	-	$-40 \sim +85$	$^{\circ}\text{C}$	-
15	Others				



■ **DIMENSION**

1. Crystal enclosure seal : Seam Weld
2. Crystal enclosure medium : Vacuum

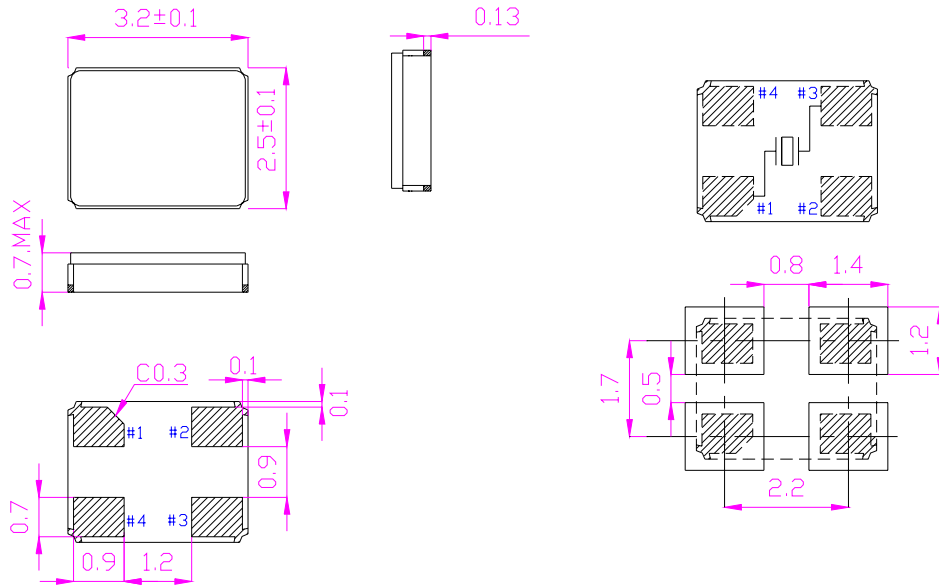

■ **MARKING**

Ref. Purchase Specification

■ **SHELF LIFE & STORAGE CONDITIONS**

No shipment is allowed by manufactured over 1 year .

Storage Conditions:

Temp.	Humidity
25±3℃	40~60%

■ **SUGGESTED REFLOW PROFILE**

Total time : 360sec.Max.

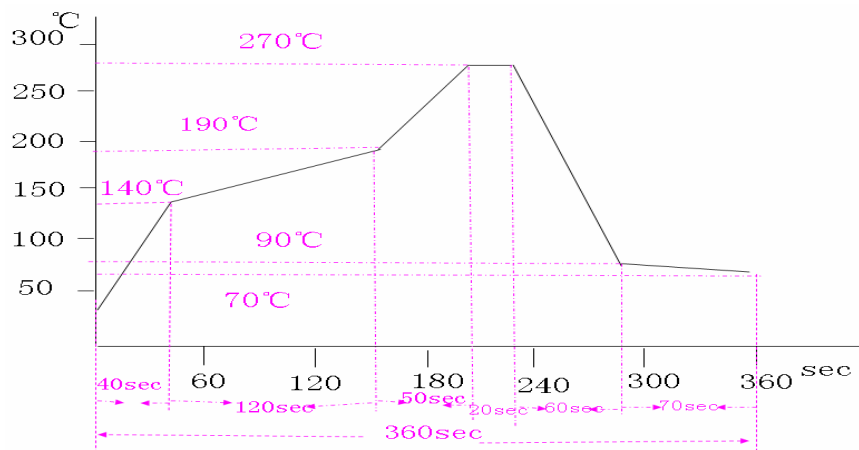

■ STRUCTURE ILLUSTRATION

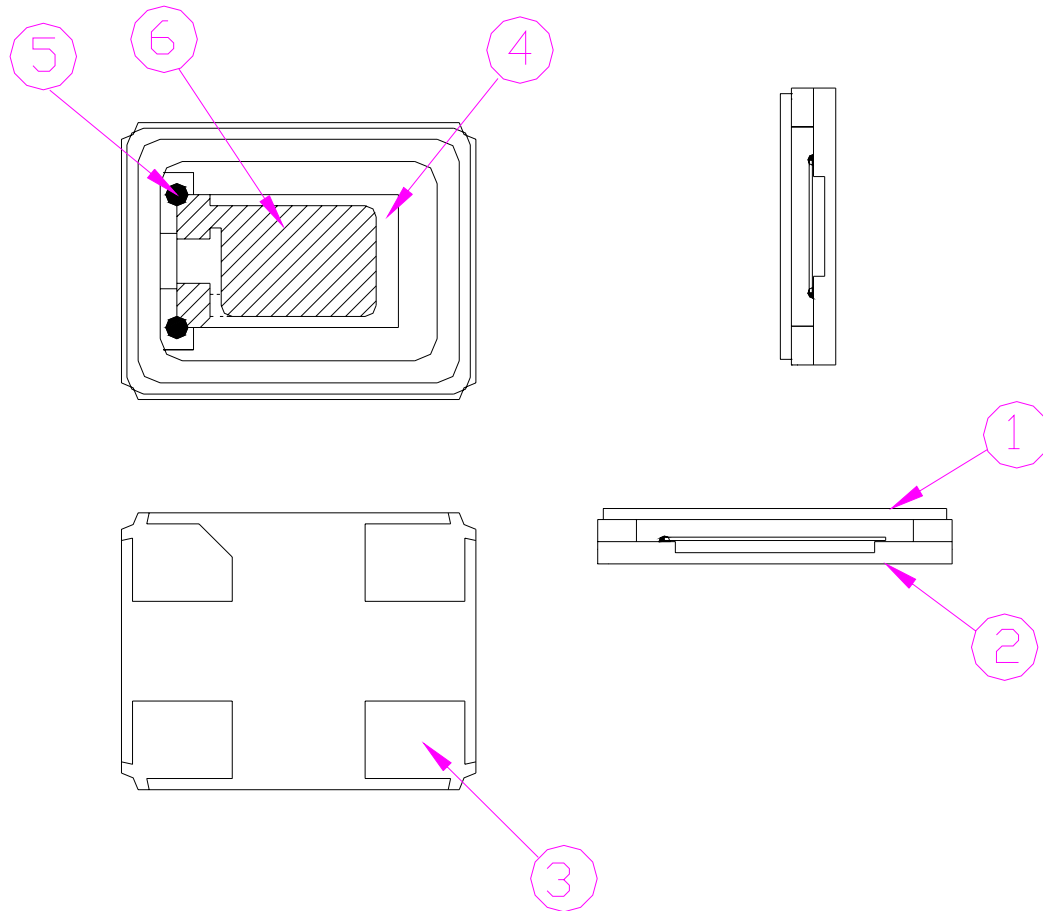

NO	COMPONENTS	MATERIALS	QTY	FINISH/SPECIFICATIONS
1	Cap	Metal (Fe)	1	-
2	Base	Ceramic	1	Color black
3	PAD	Au	4	Tungsten metalize +Ni plating +Au plating
4	Crystal blank	SiO2	1	-
5	Conductive adhesive	Ag	4	Epoxy resin
6	Electrode	合金 + Cr	2	-



- **PACKING: (EIA-481-2)**
 - Shear strength between cover and carrier tape should be 30-100g.
 - Carrier tape should be folded over three times with no break at all.

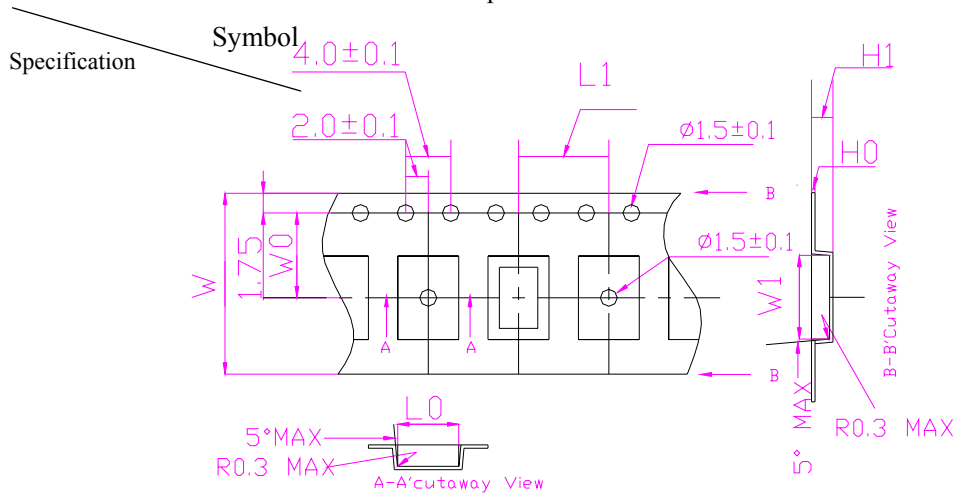

	Dimension Tolerance (mm)						
	W	W0	W1	L0	L1	H0	H1
3225-8	8 ± 0.3	3.4 ± 0.1	3.6 ± 0.1	2.7 ± 0.1	4.0 ± 0.1	0.3 ± 0.05	1.4 ± 0.1

REMARK:

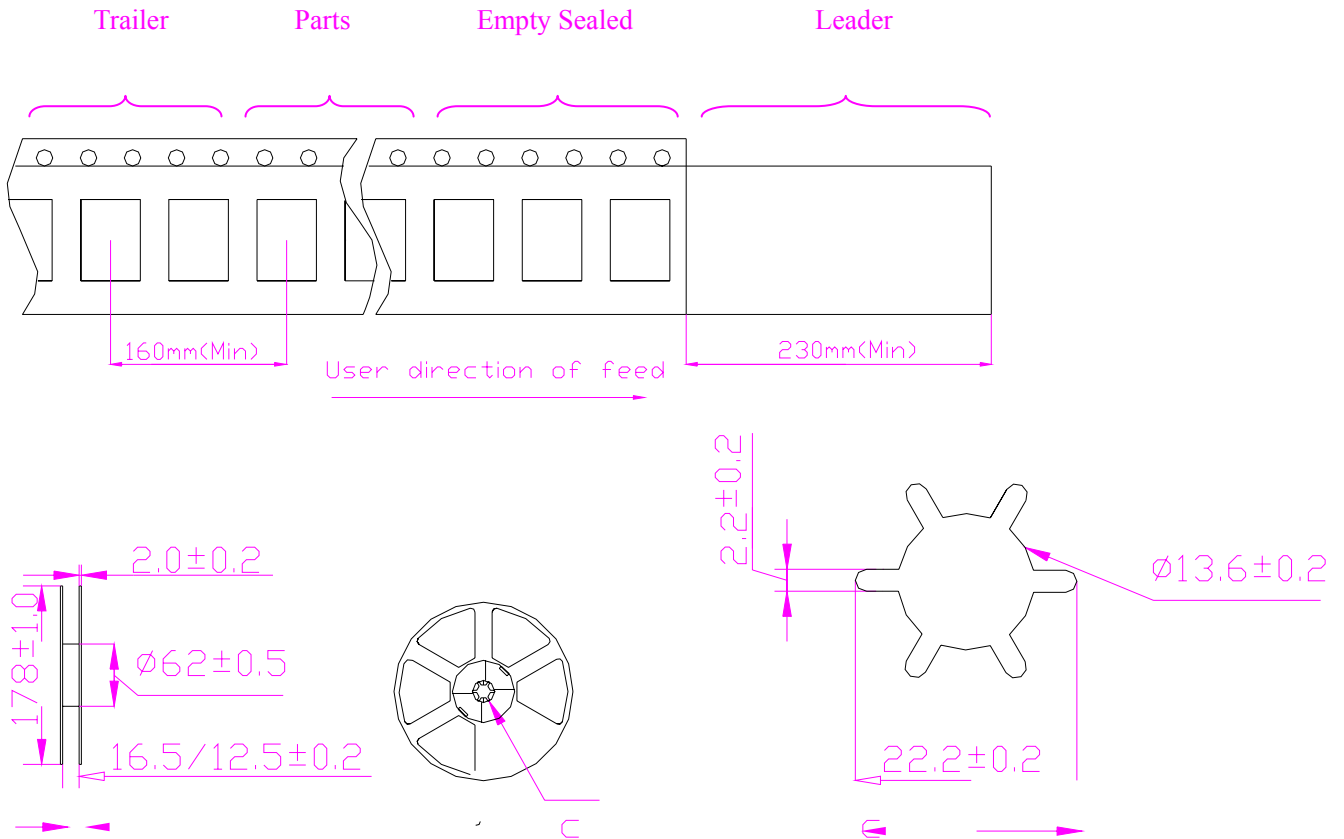

Unit : mm

Standard Reel Quantity is 1,000 pcs per reel.

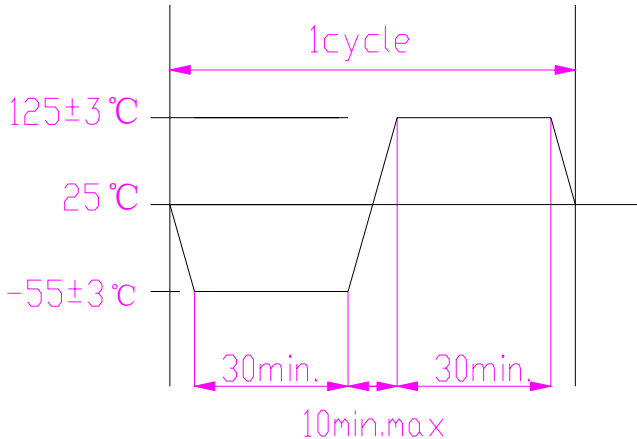

■ RELIABILITY SPECIFICATIONS

NO	Test Item	Test Methods	Ref.Doc
1	Drop test	75 cm height, fall freely onto stainless plate 3times.	-
2	Mechanical Shock	Device are shocked to half sine wave (1000G) three mutually pendicular axes each 3 times.0.5sec.duration time.	-
3	Vibration	Frequency range 10~2000Hz Amplitude 1.52mm Sweep time 20 minute Pendicular axes each test time 4 hours (Total test time 12 hours)	-
4	Solderability	Temperature $255^{\circ}\text{C} \pm 5^{\circ}\text{C}$ Immersing depth 0.5mm minimum Immersion time 10 ± 0.5 seconds Flux Rosin resin methyl alcohol Solvent (1:4)	-
5	Resistance To Soldering Heat	Pre-heat temperature 125°C Pre-heat time 60~120sec. Test temperature $260 \pm 5^{\circ}\text{C}$ Test time 5 ± 1 sec.	-
6	High Temp. Storage	$+125^{\circ}\text{C} \pm 2^{\circ}\text{C}$ for 1000 ± 12 hours	-
7	Low temp. Storage	$-40^{\circ}\text{C} \pm 2^{\circ}\text{C}$ for 1000 ± 12 hours	
8	Thermal Cycles	Total 100 cycles of the following temperature cycle 	-



环境管理物质使用规范

Specification of the environment-related substances

范围 Range	产品 Products	包材 Packing Material	Test Method
禁限物质 Banned Substances	最高含量 Maximum concentration ppm(mg/kg)	最高含量 Maximum concentration ppm(mg/kg)	
1. 镉及镉化合物 Cadmium and cadmium compounds	5	5	ICP-AES as per EN1122, method B2001 or other acid digestion.
2. 铅及铅化合物 Lead and lead compounds	40	100	ICP-AES after as per EPA 3050B or other acid digestion.
3. 汞及汞化合物 Mercury and mercury compounds	5	5	ICP-AES after as per EPA 3052 or other acid digestion.
4. 六价铬化合物 Hexavalent-Chromium VI (Cr ⁺⁶)	10	10	As per US EPA 7196A and US EPA 3060A.
5. 聚溴联苯 PBB Polybrominated biphenyls	5	5	With reference to USEPA 3540 or USEPA3550. Analysis was performed by LPLC/DAD, LC/MS or GC/MS. (prohibited by 2002/95/EC (RoHS),83/261/EEC, and76/769/EEC)
6. 聚溴二苯醚 PBDE Polybrominated diphenyl ethers	5	5	With reference to USEPA3540or USEPA3550. Analysis was performed by HPLC/DAD LC/MS or GC/MS.(prohibited by 2002/95/EC(RoHS), 83/264/EEC, and 76/769/EEC)
7. 多氯联苯 (PCB) Polychlorinated biphenyl	5	5	
8. 多氯化萘 (PCN) Polychlorinated naphthalene	5	5	
9. 氯代烷烃 (CP) Chlorinated paraffin	5	5	
10. 其他有机氯化物 Other chlorinated organic compounds	5	5	
11. 其他有机溴化合物 Other brominated organic compounds	5	5	
12. 有机锡化合物 (三丁基锡化合物, 三苯基锡化合物) Organic tin compounds (Tributyl tin category & Triphenyl tin category)	5	5	
13. 石棉 Asbestos	5	5	
14. 偶氮化合物 Azo compounds	5	5	
15. 甲醛 Formaldehyde	5	5	
16. 聚氯乙烯(PVC)以及聚氯乙烯混合物 Polyvinyl chloride (PVC) and PVC blends	No detect	No detect	
17. 包装材料中重金属(汞、镉、六价铬、铅、PBB、PBDE)之总量 Heavy metals (mercury, cadmium, lead, Cr ⁺⁶ ,PBB and PBDE) in packing materials	N/A	<100	

Lead Free Products are “Directive 2002/95/EC of The European Parliament of 27 January 2003 on the restriction of certain hazardous substances (RoHS) in electrical and electronic equipment” and Sony SS-00259 Compliant.



MEC