

MEC®

SPECIFICATION OF CRYSTAL UNIT

1. Nominal Frequency	16.625 MHz
2. Holder Type	HC49U
3. Frequency Tolerance	± 20 ppm at 25°C
4. Equivalent Resistance	25 Ohm max. / CL=Series
5. Insulation Resistance	500M Ohm(min) @100VDC
6. Operating Temperature Range	-10°C ~ +60°C
7. Temperature Tolerance	± 20 ppm at -10°C ~ +60°C
8. Loading Capacitance	33pF
9. Drive Level	100µW max.
10. Oscillation Mode	Fundamental

DIMENSIONS (mm)

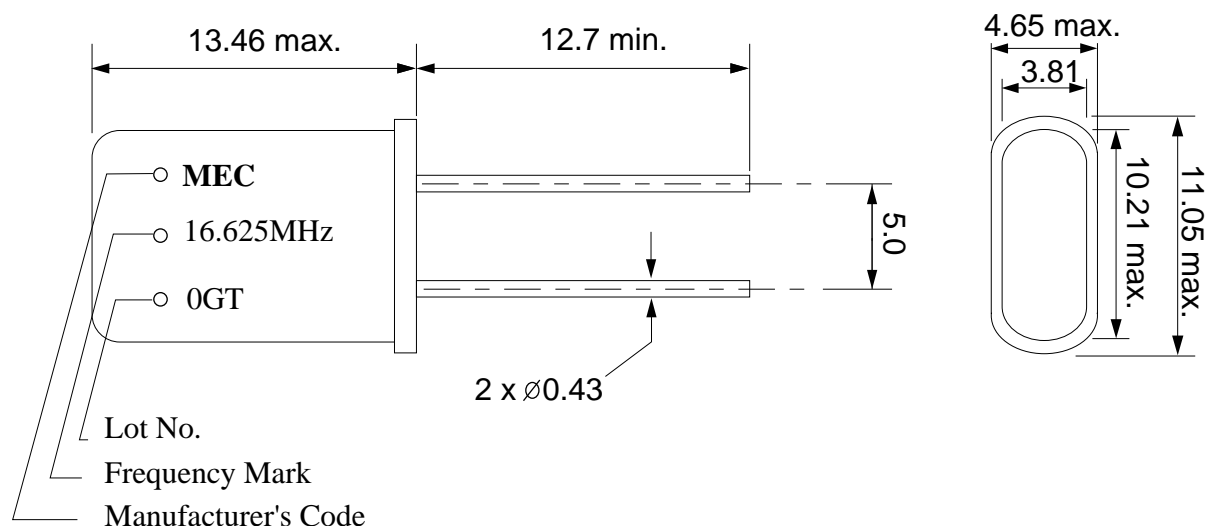

Prepared by: Leo Wong
Checked By: _____
DOC. No: HC49U-16_625MHz